



Reel Mower

TRM-3083



Parts Manual

Locke Turf

307 Highway 52E, Opp, Alabama 36467, (334) 493-1300

General Information

Mower Layout

Please note that “Left” and “Right” are determined by standing at the rear of the mower and facing forward.

Mowing units are numbered from 1 to 7, as shown. Note that 5 reel mowers do not use units 6 & 7 or any of the required mechanisms to attach them.

Quantities

Quantities shown are for each sub-assembly rather than for the complete mower.

Illustration

This illustration is to identify the Reel by number.

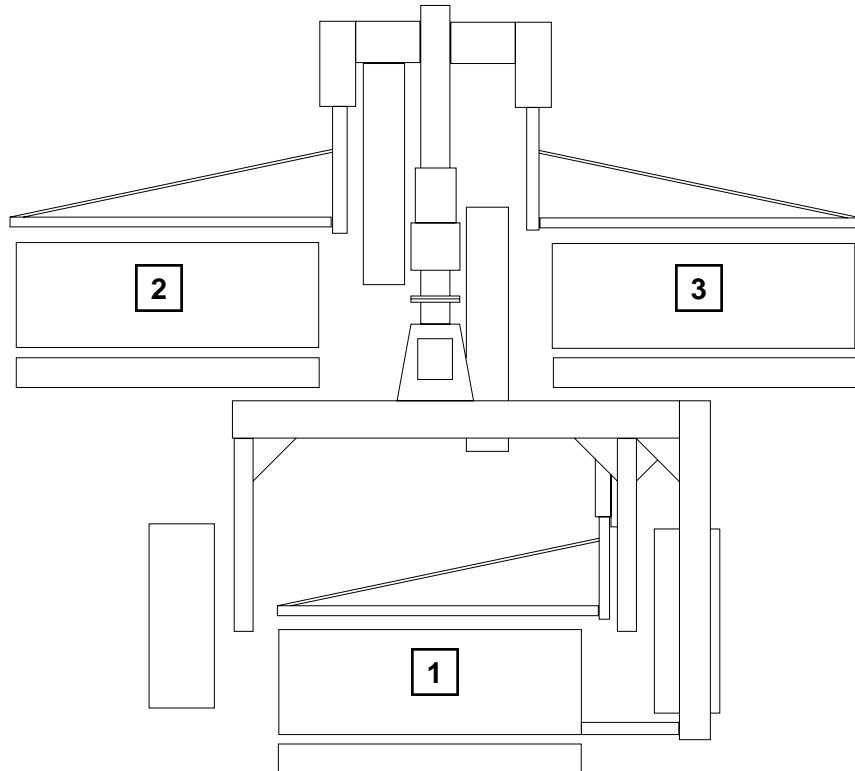

**TRM-3083
Reel Mower
Alphabetical Index**

Note: All parts that are available for repair parts are not listed in this index. Check parts listed to find unlisted parts that attach or are work in relation to listed parts.

Description	Section
Mainframe & related Parts	1
Shielding	2
Drives, Gearbox, Belts, Driveshaft	3
Wheels, Axles, Hubs	4
Hydraulics	5
Mowing Units	6
Backlapper	7
Decals	8

Parts Description	Page No.
Axle Assy. - Transport	4-1
Backlapper Assy.	7-1
Bearing - Reel	6-1
Belt - V-Belt	3-1
Brace - Tongue	1-1
Bracket - Roller Mount	6-5
Bushing - Roller Adapter	6-5
Chains - Lift (TRM-3083 3-Gang)	1-2
Compensator, Double	1-3
Compensator, Single	1-4
Cutting Units	6-2, 6-3
Cylinder, Hydraulic	5-1
Decal Kit	8-1, 8-2
Driveshaft - Input CV Tractor to Implement	3-3
Fittings - Hydraulic	5-1
Gearbox & Related Parts	3-1
Hitch - Ball Type	1-1
Hitch - Swivel	1-1
Hose Holder	1-1
Hose - Hydraulic	5-1
Housing - Reel Bearing	6-1
Hub Assy. - Transport	4-1
Idler Assy. - Belt	3-6
Jackshaft Assy. - Front	3-4
Jackshaft Assy. - Rear	3-5
Jackstand	1-1
Lift, Wing	1-2
Mainframe (TRM-3083 3-Gang)	1-1
Roller Assemblies	6-5
Seal Kit - Hydraulic Cylinder	5-1
Sheaves - From Gearbox	3-1
Shields - Driveshaft & Gearbox	2-1
Shields - LH / RH Drive Guards	2-1
Shield - V-Belt Guard	2-2
Stabilizer Arm	6-4
Telescoping Arm	6-4
Tie Rod Assy. Compensator	1-3
Tongue	1-1
Wheel Assy.	4-1

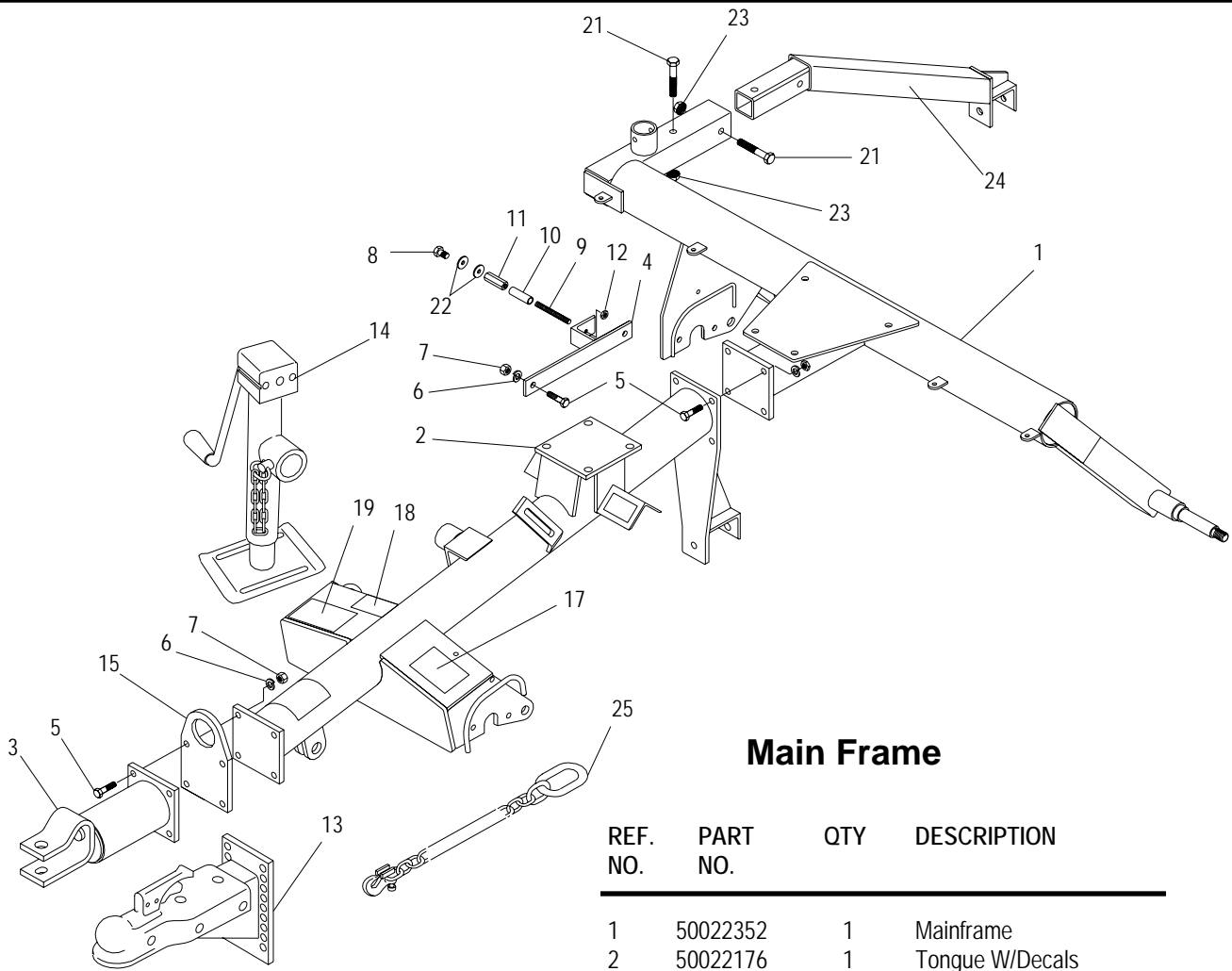

Main Frame

REF. NO.	PART NO.	QTY	DESCRIPTION
1	50022352	1	Mainframe
2	50022176	1	Tongue W/Decals
3	50019541	1	Swivel
4	50019888	1	Tongue Brace, RH
5	15093	10	HHCS 1/2"-13 x 1-1/2" Gr.5
6	15806	10	Lock washer 1/2"
7	8151600	10	Hex Nut 1/2"
8	44721	1	HHCS 3/8"-16 x 3/4" Gr.5
9	50019944	1	Stud, Belt Guard
10	50022437	1	Spacer, RH Shield
11	44600	1	Nut, Coupling 3/8"-16 x 1-3/4"
12	10151200	1	Hex Nut, Jam 3/8-16
13	50019542	1	Ball Hitch Assy.
14	50022109	1	Jackstand Assy.
15	50019877	1	Hose Holder Assy.
16	50022073	1	Warning Decal
17	50022081	1	Notice Decal
18	50022067	1	Decal, Flag
19	50022070	1	Warning Decal
20	50022066	2	Danger Decal
21	20864	1	HHCS 1/2"-13 x 3" Gr.5
22	15830	2	Flatwasher 3/8"
23	44615	2	Whiz Nut 1/2"-13
24	50022355	1	Compensator Arm
25	91091	1	Safety Tow Chain

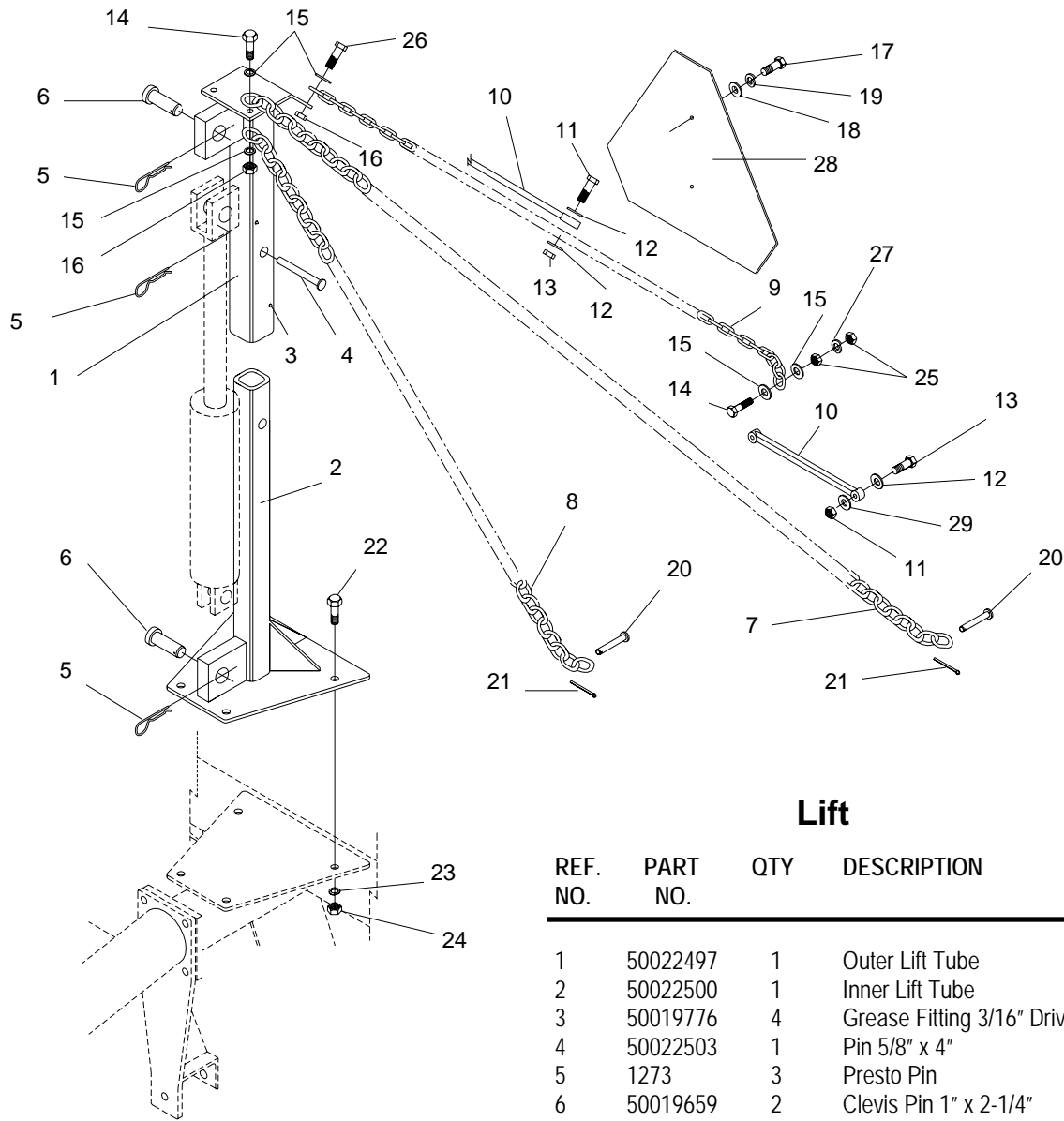

Lift

REF. NO.	PART NO.	QTY	DESCRIPTION
1	50022497	1	Outer Lift Tube
2	50022500	1	Inner Lift Tube
3	50019776	4	Grease Fitting 3/16" Drive In
4	50022503	1	Pin 5/8" x 4"
5	1273	3	Presto Pin
6	50019659	2	Clevis Pin 1" x 2-1/4"
7	50022337	2	Lift Chain - Outer Front
8	50022336	2	Lift Chain - Inner Front
9	50022335	2	Lift Chain - Rear
10	50022099	3	Strap, Rubber 8.25" Long
11	20016	6	HHCS 1/4" x 1-1/2"
12	15918	12	Flatwasher 1/4"
13	44539	6	Hex Nut 3/8" Nylock
14	44181	4	HHCS 3/8"
15	15830	10	Flatwasher 3/8"
16	44601	4	Hex Nut 3/8" -Nylock
17	1161006	2	HHCS 5/16" x 3/4" Gr.5
18	15907	2	Flatwasher 5/16"
19	15808	2	Lockwasher 5/16"
20	25H49039	4	Pin 3/8" x 1-3/4"
21	15093	4	HHCS 1/2" x 1-1/2" Gr.5
22	15806	4	Lockwasher 1/2"
23	8151600	4	Hex Nut 1/2"
24	10151200	4	Jam Nut 3/8"
25	20035	2	HHCS 3/8" x 1/2"
26	15812	2	Lockwasher 3/8"
27	50019854	1	SMV Sign
28	50019644	8	Fender Washer 1/4" x 1"

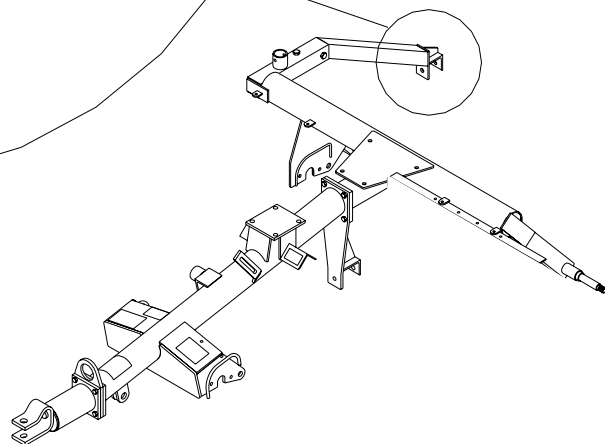
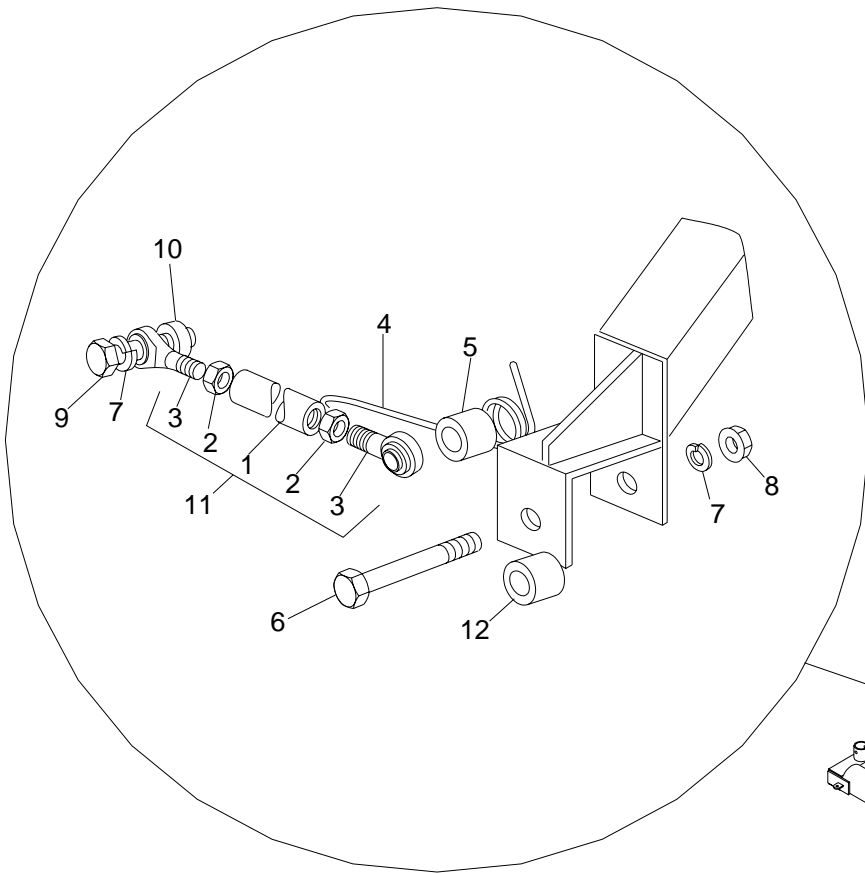

**Single Compensator and Tie
Rod Assemblies
Reel Unit No. 1**

REF. NO.	PART NO.	QTY	DESCRIPTION
1	50019910	1	Tie Rod
2	44743	1	Hex Nut 5/8"-18 UNF RH Thd
	44710	1	Hex Nut 5/8"-18 UNF LH Thd
3	50019870	1	Rod End 5/8" Bore w/Rh Thread 5/8"-18
	50019868	1	Rod End 5/8" Bore w/LH Thread 5/8"-18
4	50022083	1	Compensator Spring 1/4"
5	50019940	1	Spacer 7/8" Thick
6	44168	1	HHCS 5/8"-11 x 3-3/4" Gr.5
7	19486	1	Lockwasher 5/8"
8	15563	1	Hex Nut 5/8"-11
9	20947	1	HHCS 5/8"-11 x 2" Gr.5
10	50019875	1	Tie Rod Spacer
11	50019911	1	Tie Rod Assy.
12	50019941	1	Spacer 5/8" Thick

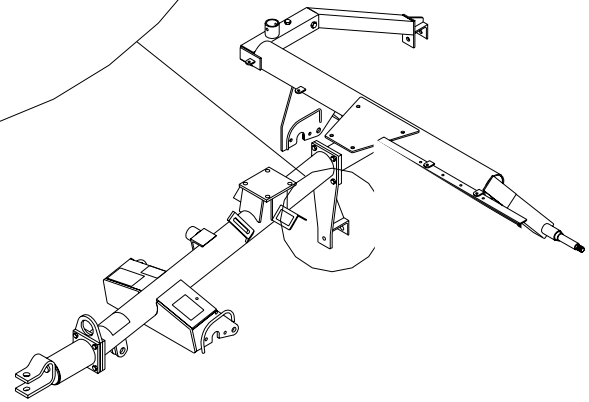
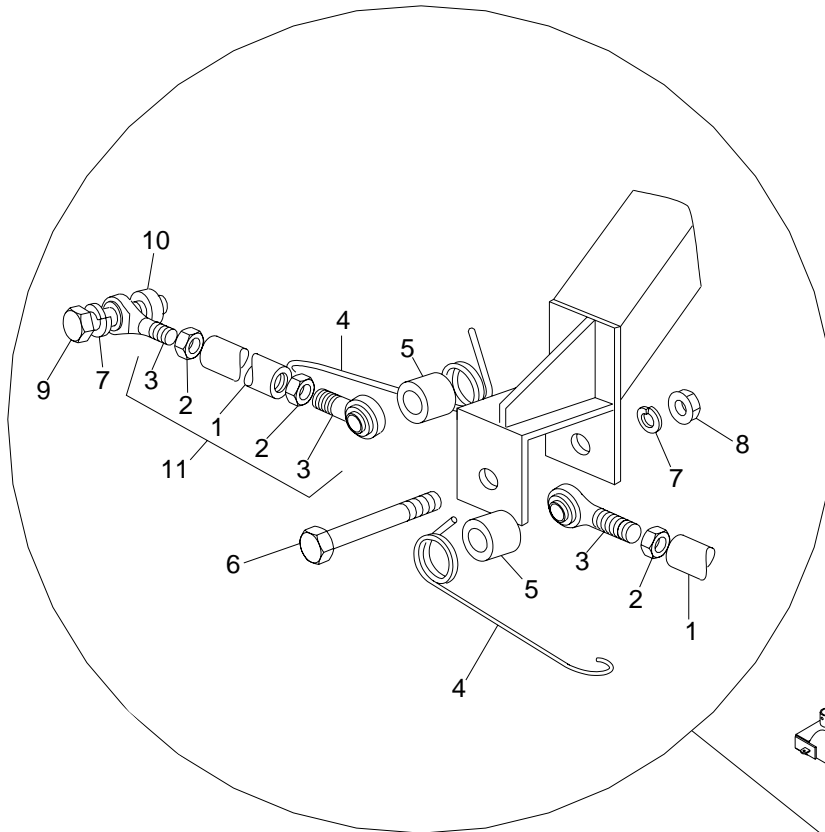

**Dual Compensator and Tie Rod
Assemblies
Reel Units 2 & 3**

REF. NO.	PART NO.	QTY	DESCRIPTION
1	50019910	1	Tie Rod
2	44743	1	Hex Nut 5/8"-18 UNF RH Thd
	44710	1	Hex Nut 5/8"-18 UNF LH Thd
3	50019870	1	Rod End 5/8" Bore w/Rh Thread 5/8"-18
	50019868	1	Rod End 5/8" Bore w/LH Thread 5/8"-18
4	50022083	1	Compensator Spring 1/4"
5	50019940	1	Spacer 7/8" Thick
6	44625	1	HHCS 5/8"-11 x 4-3/4" Gr.5
7	19486	1	Lockwasher 5/8"
8	15563	1	Hex Nut 5/8"-11
9	20947	1	HHCS 5/8"-11 x 2" Gr.5
10	50019875	1	Tie Rod Spacer
11	50019911	1	Tie Rod Assy.

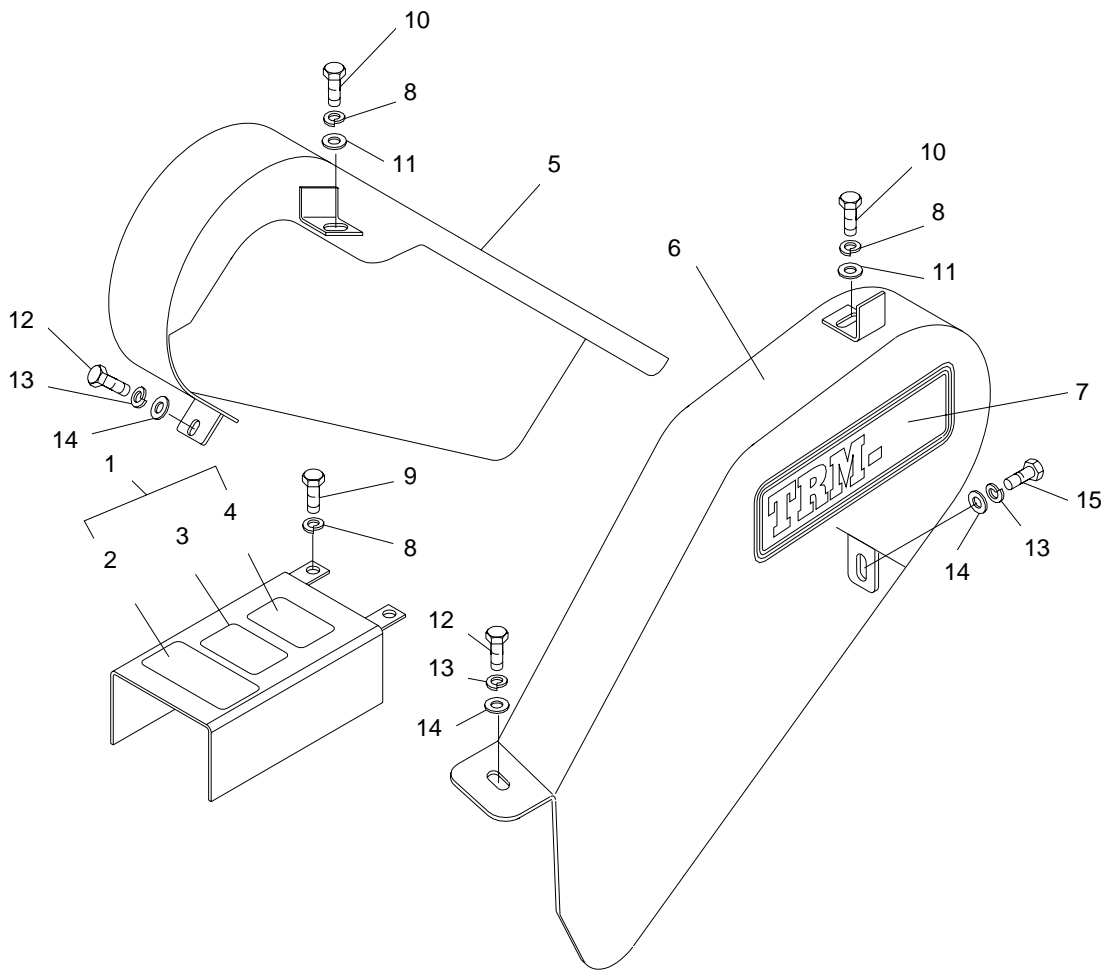

Primary Guards

REF. NO.	PART NO.	QTY	DESCRIPTION
1	50022175	1	Guard w/Decals - Driveshaft
2	50022072	1	Danger Decal
3	50022074	1	Decal - Notice to Owner
4	50022065	1	Danger Decal (Spanish)
5	50019968	1	R.H. Drive Guard
6	50019971	1	L.H. Drive Guard
7	50100034	2	Model Decal TVM-5130
	50100033	2	Model Decal TVM-3077
8	15806	4	Lockwasher 1/2"
9	44588	2	HHCS 1/2"-13 x 3/4" Gr.5
10	20054	2	HHCS 1/2"-13 x 1" Gr.5
11	15829	2	Flatwasher 1/2"
12	20035	2	HHCS 3/8"-16 x 1/2"
13	15812	3	Lockwasher 3/8"
14	15830	3	Flatwasher 3/8"
15	1161006	1	HHCS 5/16"-18 x 3/4"

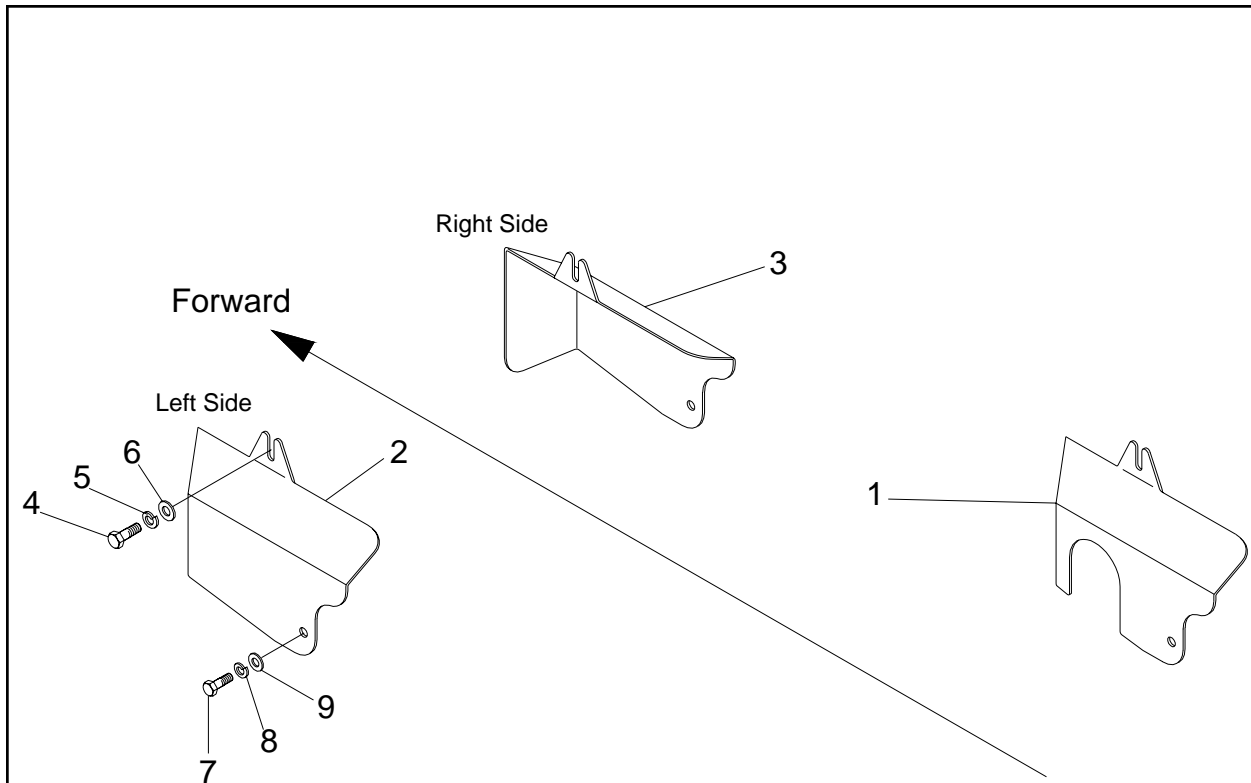

V-Belt Guards

REF. NO.	PART NO.	QTY	DESCRIPTION
1	50019931	1	Guard, Center Rear #1
2	50019933	1	Guard, L.H. Outside #2 & #4
3	50019934	1	Guard, R.H. Outside #3 & #5
4	1161006	5	HHCS 5/16"-18 x 3/4"
5	15801	5	Lockwasher 5/16"
6	15907	5	Flatwasher 5/16"
7	20009	5	HHCS 1/4"-20 x 1/2"
8	15905	5	Lockwasher 1/4"
9	15918	5	Flatwasher 1/4"

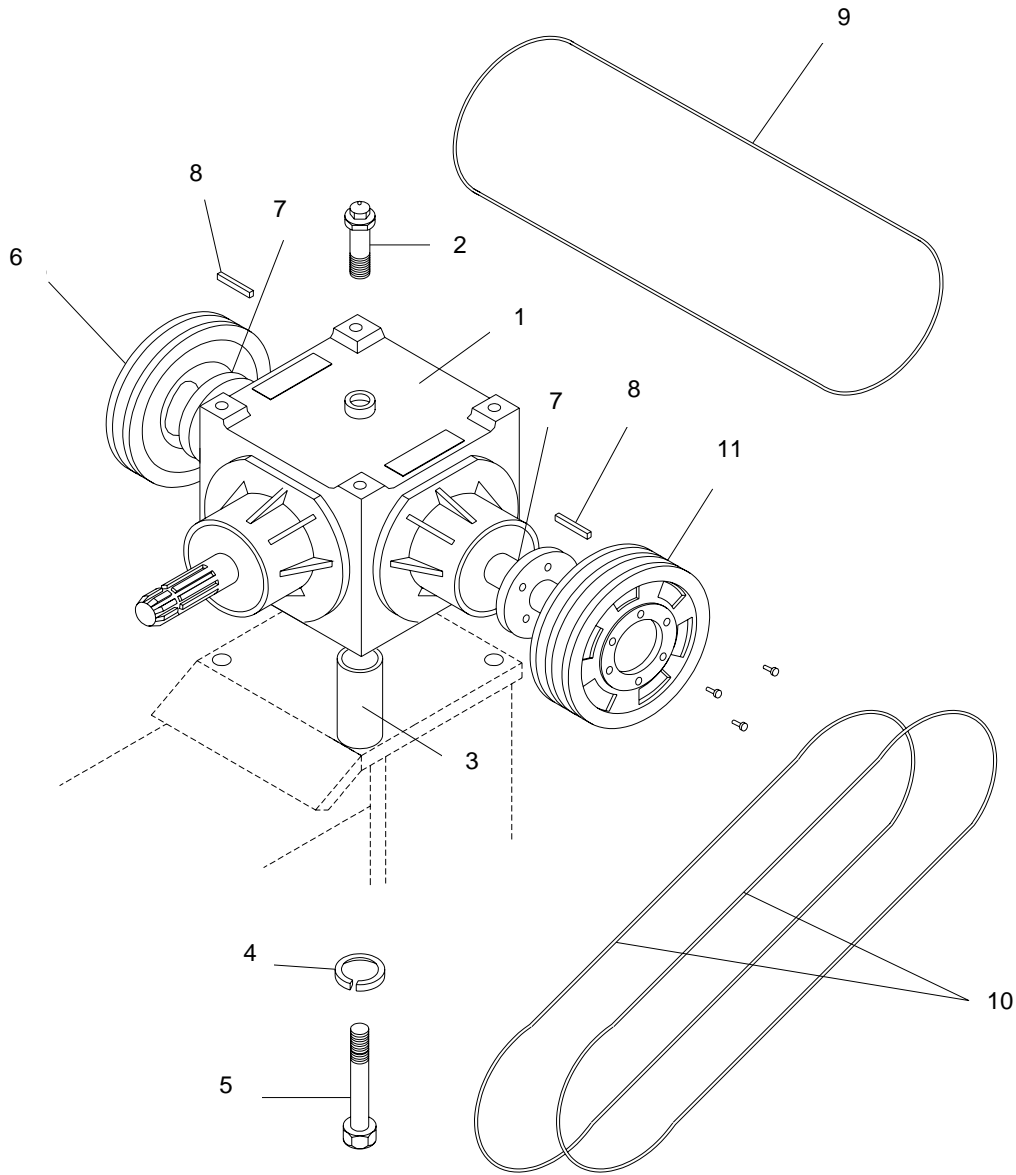

Gearbox & Sheaves

REF. NO.	PART NO.	QTY	DESCRIPTION
1	50019729	1	Gearbox Assy. (Omni) TVM-3077
2	50022324	1	Vent Plug
3	50019943	1	Spacer, Gearbox
4	15806	4	Lockwasher 1/2"
5	20864	4	HHCS 1/2"-13 x 3" Gr.5
6	50022086	1	Pulley, 1 Belt 7" Dia.
7	50022108	2	Bushing, Tapered Split SDS 1-1/8"
8	65485	2	Key 2"
9	50022450	3	"V"-Belt BX-78
10	50022451	2	"V"-Belt BX-70
11	50022085	1	Pulley, 2 Belt, 7" Dia.

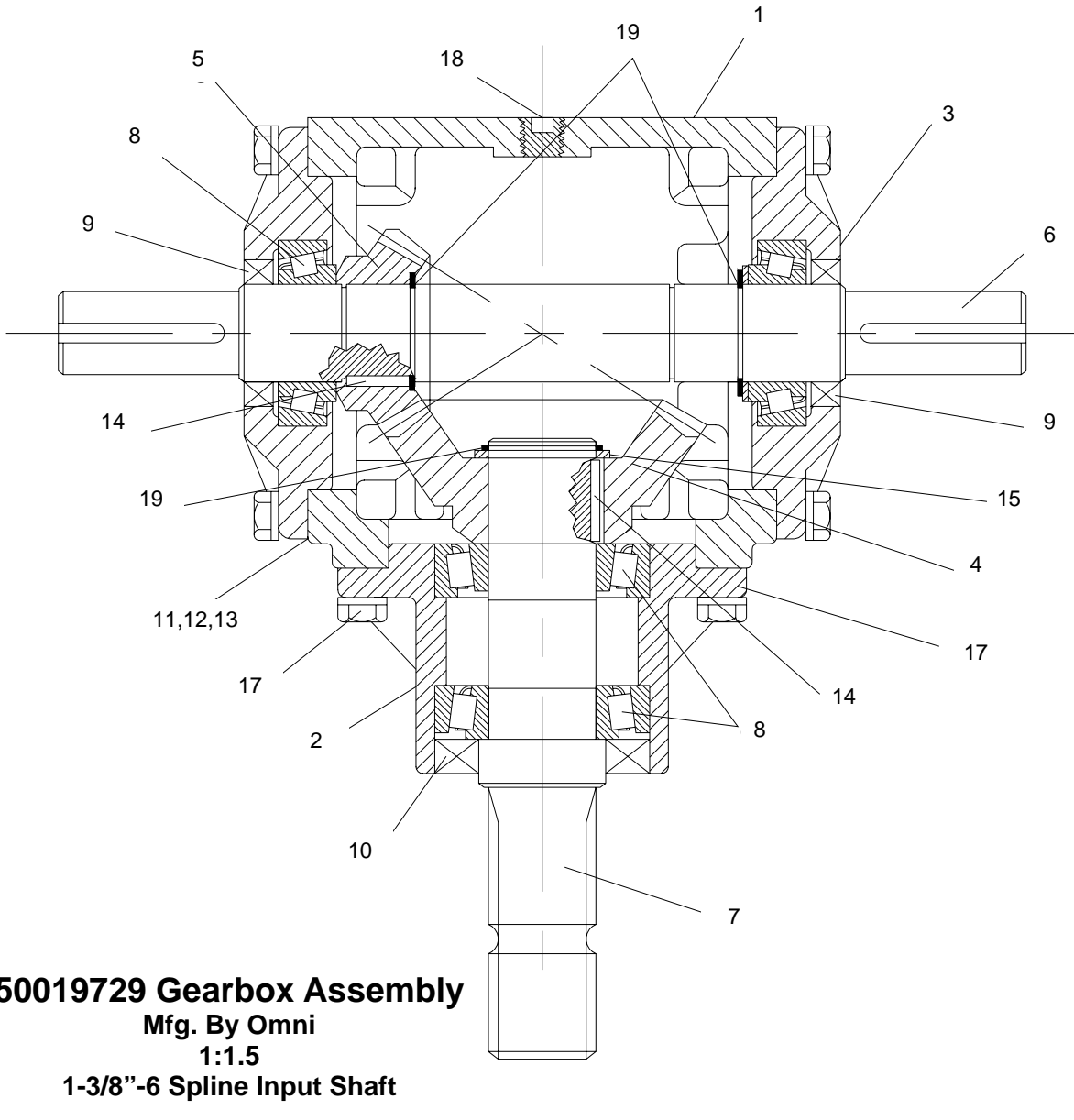

50019729 Gearbox Assembly
Mfg. By Omni
1:1.5
1-3/8"-6 Spline Input Shaft

REF. NO.	PART NO.	QTY	DESCRIPTION	REF. NO.	PART NO.	QTY	DESCRIPTION
1	50022476	1	Housing	11	50022487	A/R	Gasket, Cap, 0.1
2	50022477	1	Cap, Cantilevered	12	50022488	A/R	Gasket, Cap, 0.2
3	50022478	2	Cap, Thru	13	50022489	A/R	Gasket, Cap, 0.3
4	50022479	1	Gear, 24T	14	50022490	2	Key, Square 10 x 25mm
5	50022480	1	Pinion, 16T	15	50022491	2	Spacer
6	50022481	1	Shaft, Output	16	1161010	24	HHCS 5/16" x 1" Gr.5
7	50022482	1	Shaft, Input	17	15808	24	Lockwasher 5/16"
8	70797	4	Bearing, 30207	18	78719	2	Plug, Socket Hd. 1/2"-14 NPTF
9	50022485	2	Seal, Thru Cap	19	50022493	4	Retaining
10	50022486	1	Seal, Cant. Cap				

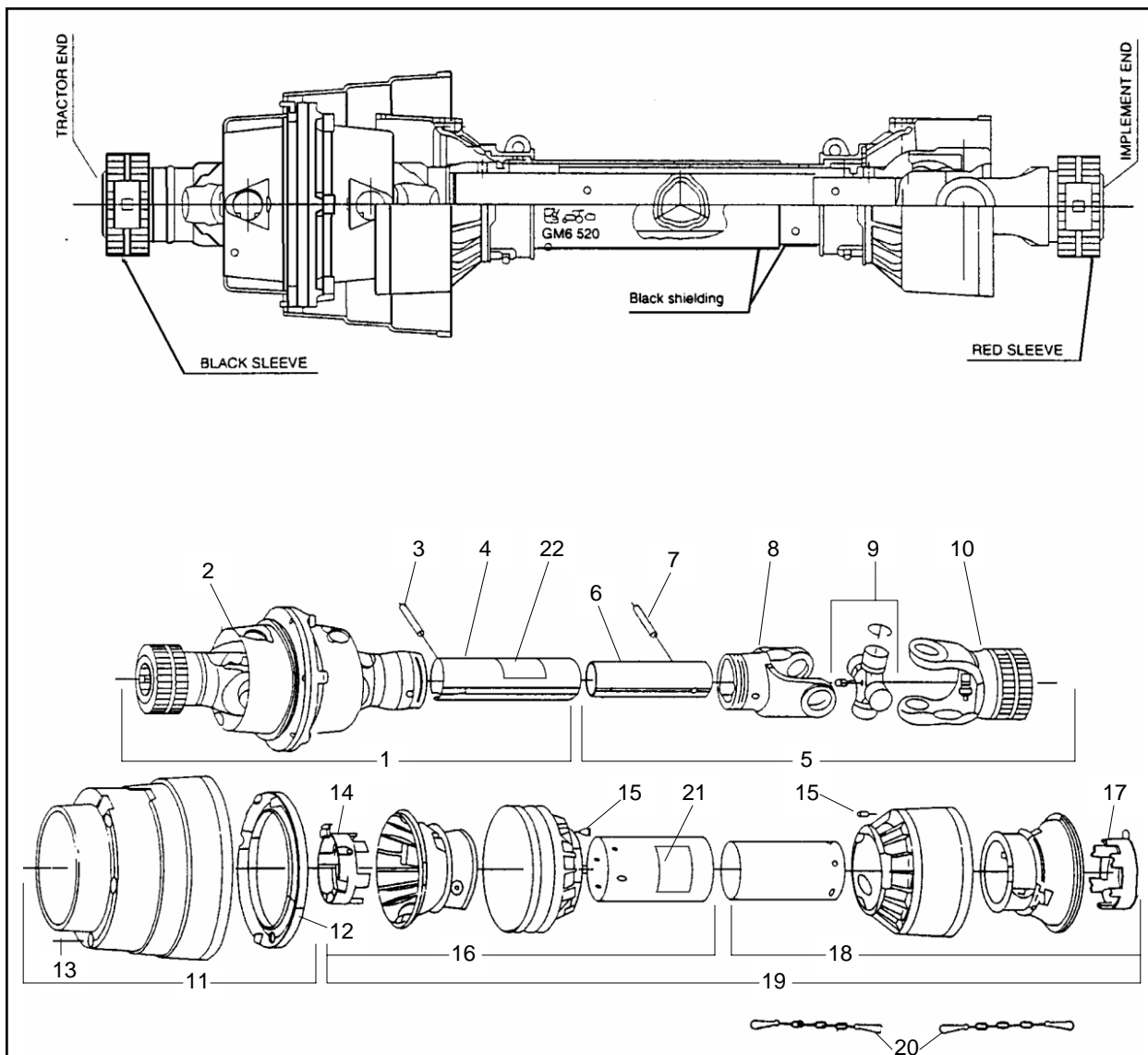

50022104 P.T.O. Shaft and Parts

REF. NO.	PART NO.	QTY	DESCRIPTION	REF. NO.	PART NO.	QTY	DESCRIPTION
1	50022676	1	Half Shaft, Outer	12	50022686	1	Bearing, Soft Cone
2	50022677	1	CV Joint Assembly	13	50022687	6	Screw, Self Tapping
3	50022678	1	Roll Pin 8mm x 65mm	14	50022688	1	Bearing, Shield Tube Outer
4	50022679	1	Outer Tube	15	50022669	2	Lock Pin
5	50022680	1	Half Shaft, Inner	16	50022675	1	Outer Half Shaft Shield
6	50022681	1	Inner Tube	17	50022689	1	Bearing, Shield Tube, Inner
7	50022682	1	Roll Pin 8mm x 55mm	18	50022690	1	Inner Half Shaft Shield
8	50022692	1	Yoke, Inner Tube	19	50022691	1	Complete Shield
9	64694	1	Cross Bearing Kit	20	50022673	3	Safety Chain
10	50022684	1	Yoke, Implement End	21	78608	1	Danger Decal
11	50022685	1	Wide Angle Shield	22	78786	1	Danger Decal

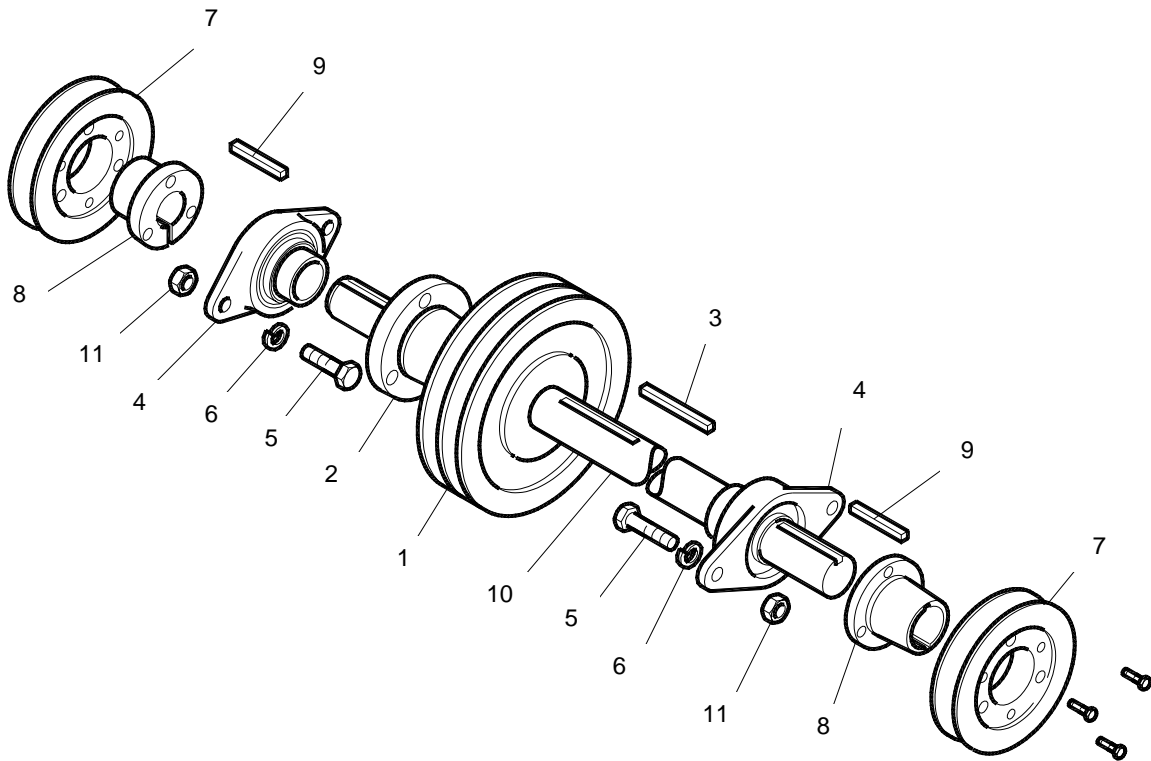

Front Jackshaft Assembly

REF. NO.	PART NO.	QTY	DESCRIPTION
1	50022087	1	Pulley 2 Belt 6.6PD
2	50022106	1	Bushing Split Taper SDS 1"
3	65484	1	Key 2"
4	50022101	2	Bearing 1" 2 Hole Flange
5	44614	4	HHCS 7/16"-14 x 1-1/4" Gr.5
6	15819	4	Lockwasher 7/16"
7		2	Pulley 1 Belt 4.4 PD
8	50022105	2	Bushing Split Taper SH 1"
9	93810	2	Key 1" x 1/4"
10	50019878	1	Front Jackshaft
11	8151400	4	Hex Nut 7/16"-14 Gr.5

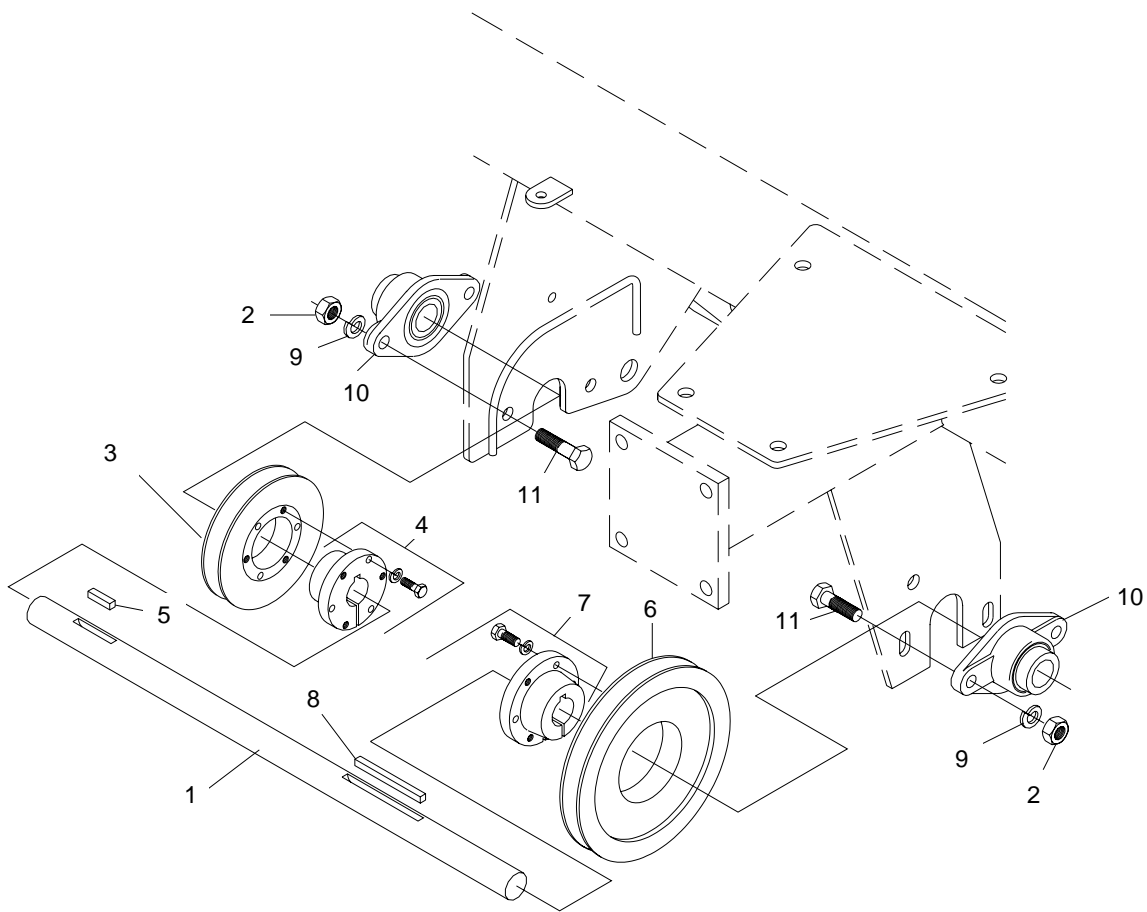

Rear Jackshaft Assembly

REF. NO.	PART NO.	QTY	DESCRIPTION
1	50022334	1	Jackshaft, Rear-3 Gang
2	8151400	4	Hex Nut 7/16"-14 Gr5
3	50022084	1	Pulley, 1 Belt 4.4" PD
4	50022105	1	Bushing, Split Taper SH 1"
5	93810	1	Key 1/4" x 1/4" x 1"
6	50022088	1	Pulley, 1 Belt 6.6" PD
7	50022106	1	Bushing, Split Taper SDS 1"
8	50019884	1	Key 1/4" x 1/4" x 3"
9	44618	4	Lockwasher 7/16"
10	50022101	2	Bearing, 2 Bolt Flange 1" Bore
11	15012	4	HHCS 7/16"-14 x 1-1/2"

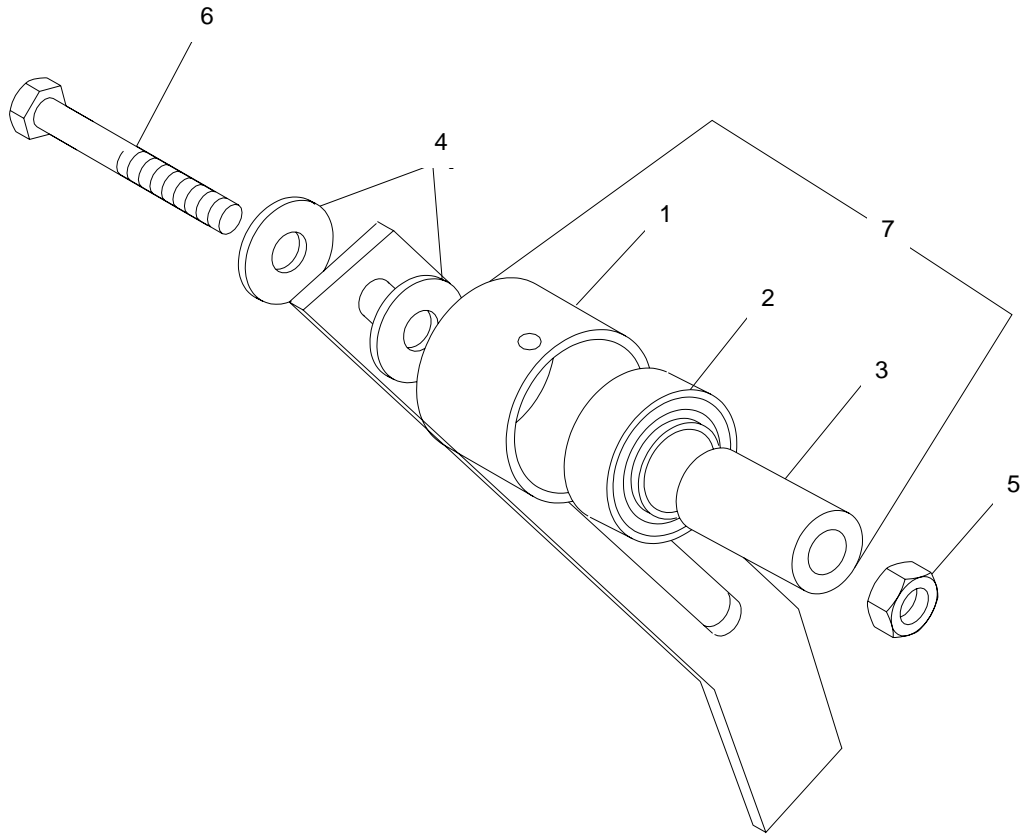

Belt Idler Assembly

REF. NO.	PART NO.	QTY	DESCRIPTION
1	50019889	1	Idler Shell 2-1/2"
	50019912	1	Idler Shell 2"
2	50019890	1	Bearing, 1" ID x 52 mm OD
3	50019891	1	Bushing 1" OD x 2"
4	15829	2	Flatwasher 1/2"
5	44539	1	Nylock Hex Nut 1/2"-13
6	20864	1	HHCS 1/2"-13 x 3" Gr.5
7	50019892	1	Belt Drive Idler Assy. 2-1/2"
	50019913	1	Belt Drive Idler Assy. 2"

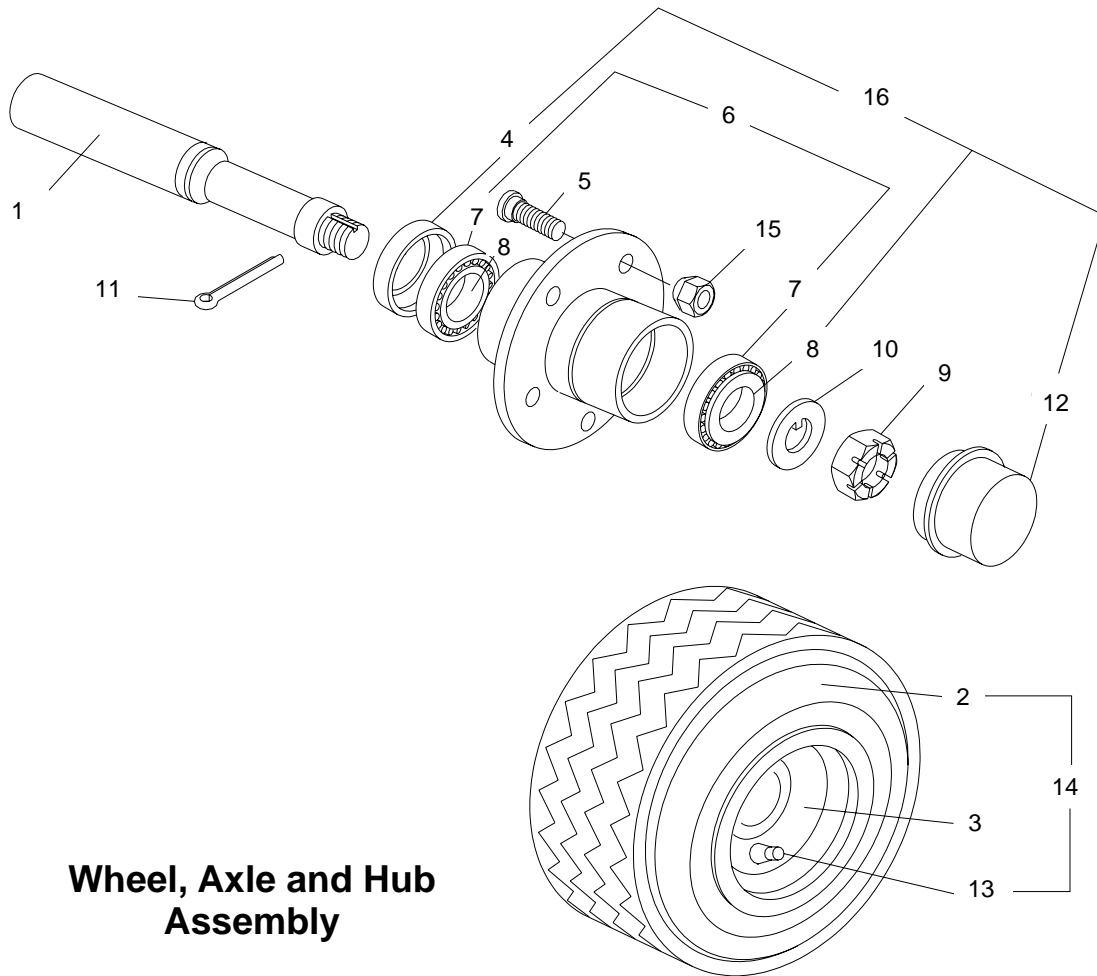

Wheel, Axle and Hub Assembly

REF. NO.	PART NO.	QTY	DESCRIPTION
1	50019879	1	Axle 10"
2	50022630	1	Tire, 18 x 8.5 x 8 (Ribbed) TVM-5130
	50022625	1	Tire, 18 x 8.5 x 8 (Highway) TVM-5130
	50022628	1	Tire, 16 x 6.5 x 8 (Ribbed) TVM-3077
3	50022626	1	Wheel 8 x 7-5 Bolt, TVM-5130
	50022629	1	Wheel 8 x 5-3/8", 5 Bolt, TVM-3077
4	50022632	1	Seal
5	52012	5	Wheel Stud 1/2"-20 x 1-7/8"
6	50022631	1	Hub w/ Cups
7	170	2	Bearing Cup L44610
8	22	2	Bearing Cone L44643
9	120	1	Castle Nut 3/4"-16
10	50019662	1	Keyed Washer 3/4"
11	20166	1	Cotter Pin 1/8" x 1-1/4"
12	50022633	1	Dust Cap
13	50022627	1	Valve Stem
14	50022178	1	Ribbed Tire & Wheel Assy. TVM-5130
	50019920	1	Highway Tire & Wheel Assy. TVM-5130
	50022364	1	Highway Tire & Wheel Assy. TVM-3077
15	15515	5	Lug Nut, 1/2"-20 UNF
16	50022095	1	Hub Assy.

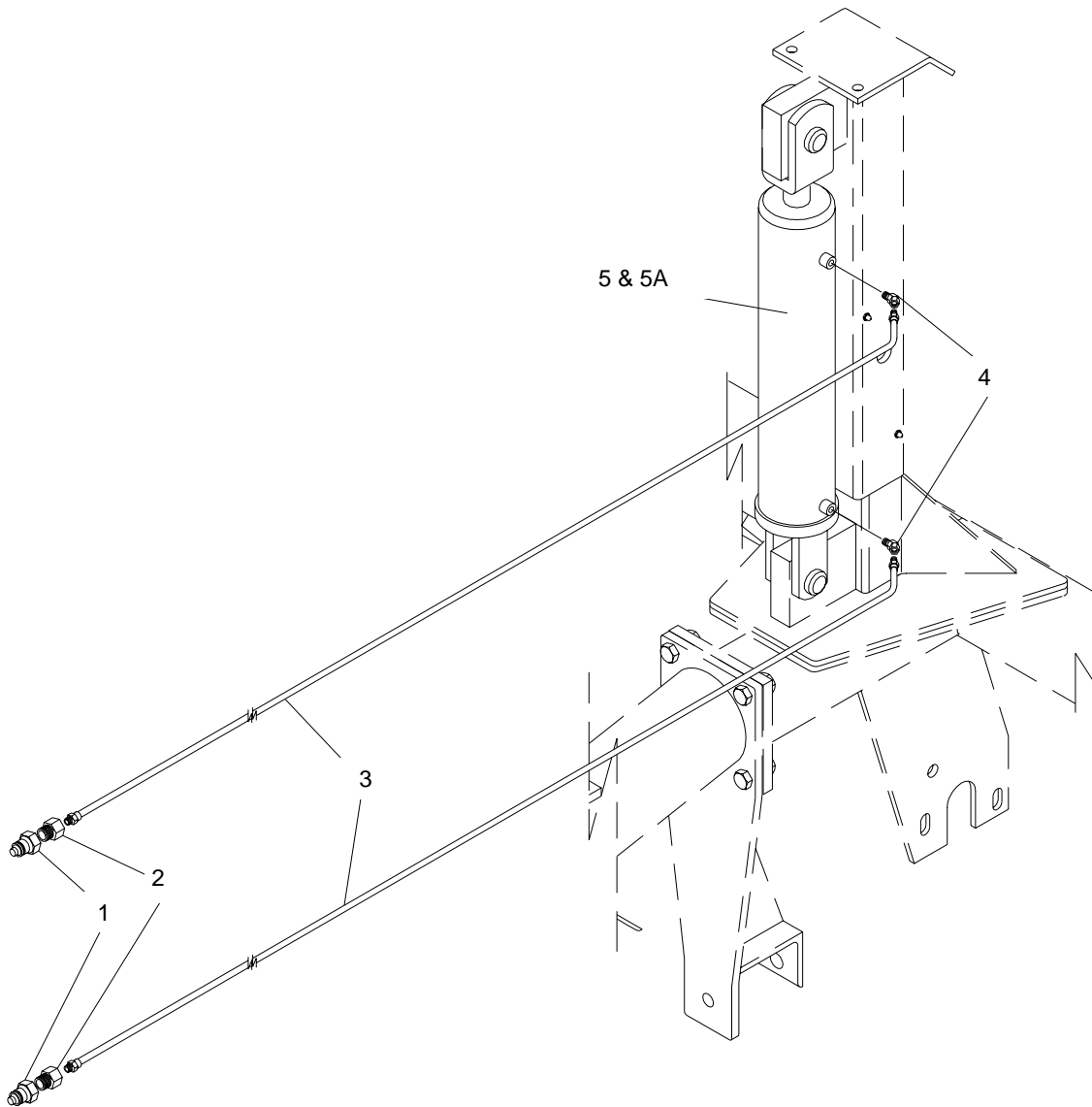

Hydraulics for Lift Bundle

REF. NO.	PART NO.	QTY	DESCRIPTION
1	50022092	2	Coupler 1/2" NPT
2	50022090	2	Adaptor 1/4" FNPT to 1/2" MNPT
3	50022091	2	Hose 1/4" FNPT to 1/2" MNPT
4	50022094	2	Elbow 45° 1/4" MNPT to 1/4" FNPT
5	50022089	2	Hydraulic Cylinder 2.5" Bore x 10" Stroke x 1-1/2" Rod Dia.
5A	50022590	1	Seal Kit for 50022089 Hydraulic Cyl.

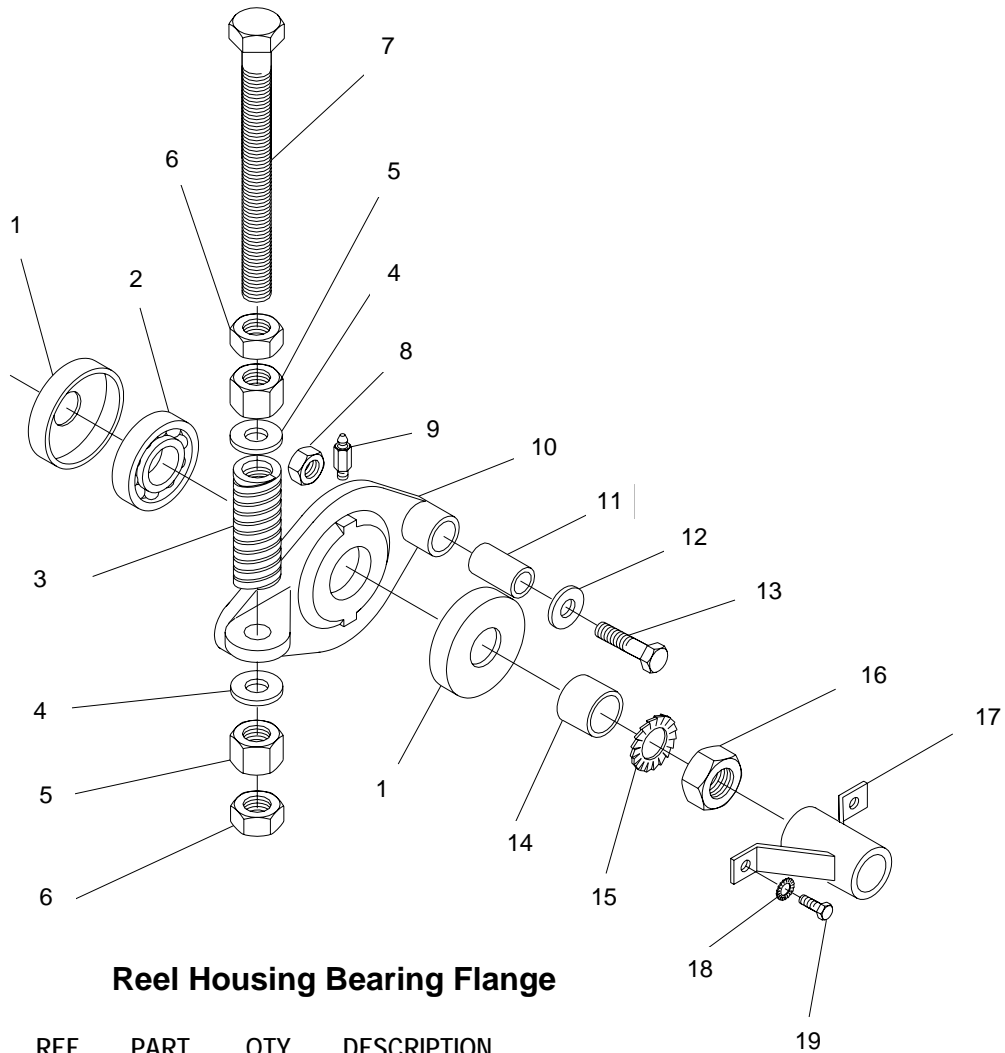

Reel Housing Bearing Flange

REF. NO.	PART NO.	QTY	DESCRIPTION
1	50022187	2	Oil Seal CR11392 Reel Bearing
2	50022189	1	Bearing
3	50022186	1	Reel Adjuster Compression Spring
4	20748	2	Flatwasher 5/8" SAE CP
5	44743	2	Hex Nut 5/8"-18
6	15653	2	Jam Nut 5/8"-18
7	44628	1	Adjustment Screw 5/8" NF x 8" G5
8	10151400	1	Jam Nut 7/16"-14
9	50022184	1	Grease Fitting Extended 1/4"-20
10	50022146	1	Bearing Housing, Reel Bearing
11	50022188	1	Pivot Bushing
12	15915	1	Flatwasher 3/8"
13	50022143	1	Reel Housing Pivot Bolt 7/16"-14
14	50022124	1	Reel Idler, End Spacer
15	44612	1	Lockwasher 3/4" External
16	44606	1	Jam Nut 3/4"-16
17	50022133	1	Safety Cup, Reel Shaft
18	44611	1	Lockwasher 3/8" External
19	20035	1	HHCS 3/8"-16 x 1/2"

Cutting Unit

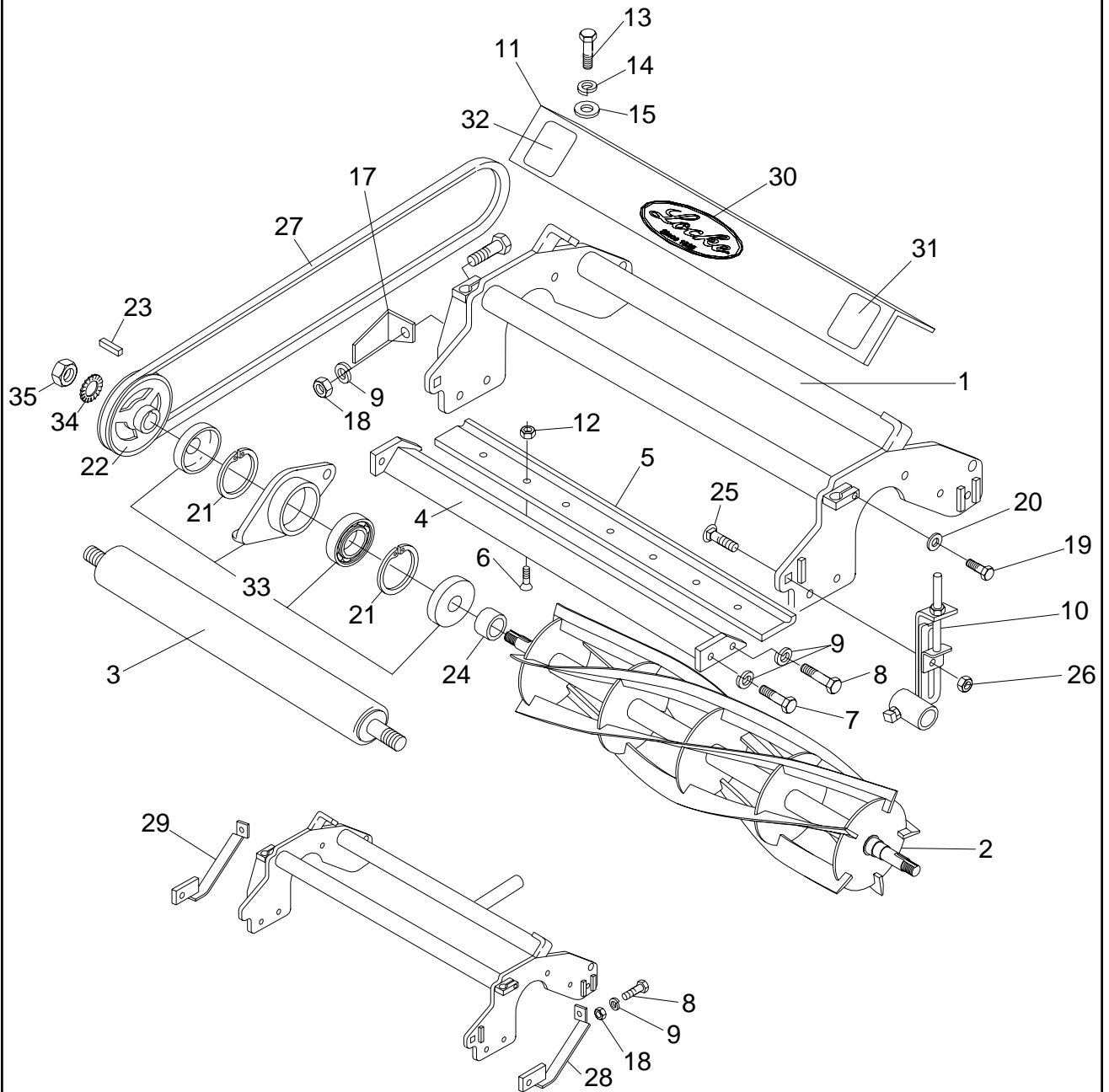

Cutting Unit

REF. NO.	PART NO.	QTY	DESCRIPTION
1	50022183	1	Reel Frame Unit #1
	50022205	1	Reel Frame Unit #2
	50022207	1	Reel Frame Unit #3
2	50019828	1	Reel, 4 Blade
	50019830	1	Reel, 5 Blade
	50019832	1	Reel, 6 Blade
	50019834	1	Reel, 7 Blade
	50019836	1	Reel, 8 Blade
	50019838	1	Reel, 9 Blade
3	50022191	1	Smooth Roller Assembly
	50022202	1	Grooved Roller Assembly
4	50022138	1	Bed Knife Holder (Bed Bar)
5	50022134	1	ARF Low Cut Bedknife
6	44552	7	Bedknife Screw 5/16"-18 x 1"
7	44610	2	HHCS 7/16"-14 x 1" Gr8
8	44614	2	HHCS 7/16"-14 x 1-1/4" Gr8
9	15819	7	Lockwasher 7/16"
10	50022154	1	Roller Bracket Assy. LH (1&2 Roller)
	50022156	1	Roller Bracket Assy. RH (1&2 Roller)
11	50022325	1	Top Shield, Mowing Unit (1)
	50022284	1	Top Shield, Mowing Unit (2&3)
12	44553	7	Hex Nut, Nylock 5/16"-18
13	1161006	2	HHCS 5/16"-18 x 3/4"
14	15808	2	Lockwasher 5/16"
15	15907	2	Flatwasher 5/16"
16	1161416	2	HHCS 7/16"-14 x 1-3/4" - 1 Roller
	44614	1	HHCS 7/16"-14 x 1-3/4" - 2 Roller
17	50022125	1	Pulley Scraper, RH (#1,2)
	50022126	1	Pulley Scraper, LH (#3)
18	8151400	3	Hex Nut 7/16"-14 Gr8
19	20034	2	HHCS 3/8"-16 x 1" Gr8
20	15812	2	Lockwasher 3/8"
21	50022185	2	Retaining Ring 2-1/2" Internal
22	50019951	1	Drive Sheave - Reel
23	20337	1	Square Key 1" x 1/4"
24	50022121	1	Reel Drive Side Spacer
25	5161614	2	Carriage Bolt 1/2"-13 x 1-1/2"
26	44539	3	Hex Nut, Nylock 1/2"-13
27	50022097	1	Belt - V B64 Reel Drive
28	50022119	1	Skid Shoe, RH
29	50022120	1	Skid Shoe, LH
30	500033	1	Locke Decal
31	50022077	1	Danger Decal
32	50022075	2	Danger Decal
33		A/R	Refer to Reel Bearing Housing Flange Parts Breakdown
34	44606	1	Jam Nut 3/4" NF CP
35	44162	1	Star Lockwasher 3/4" Ext.

Cutting Unit V-Reel

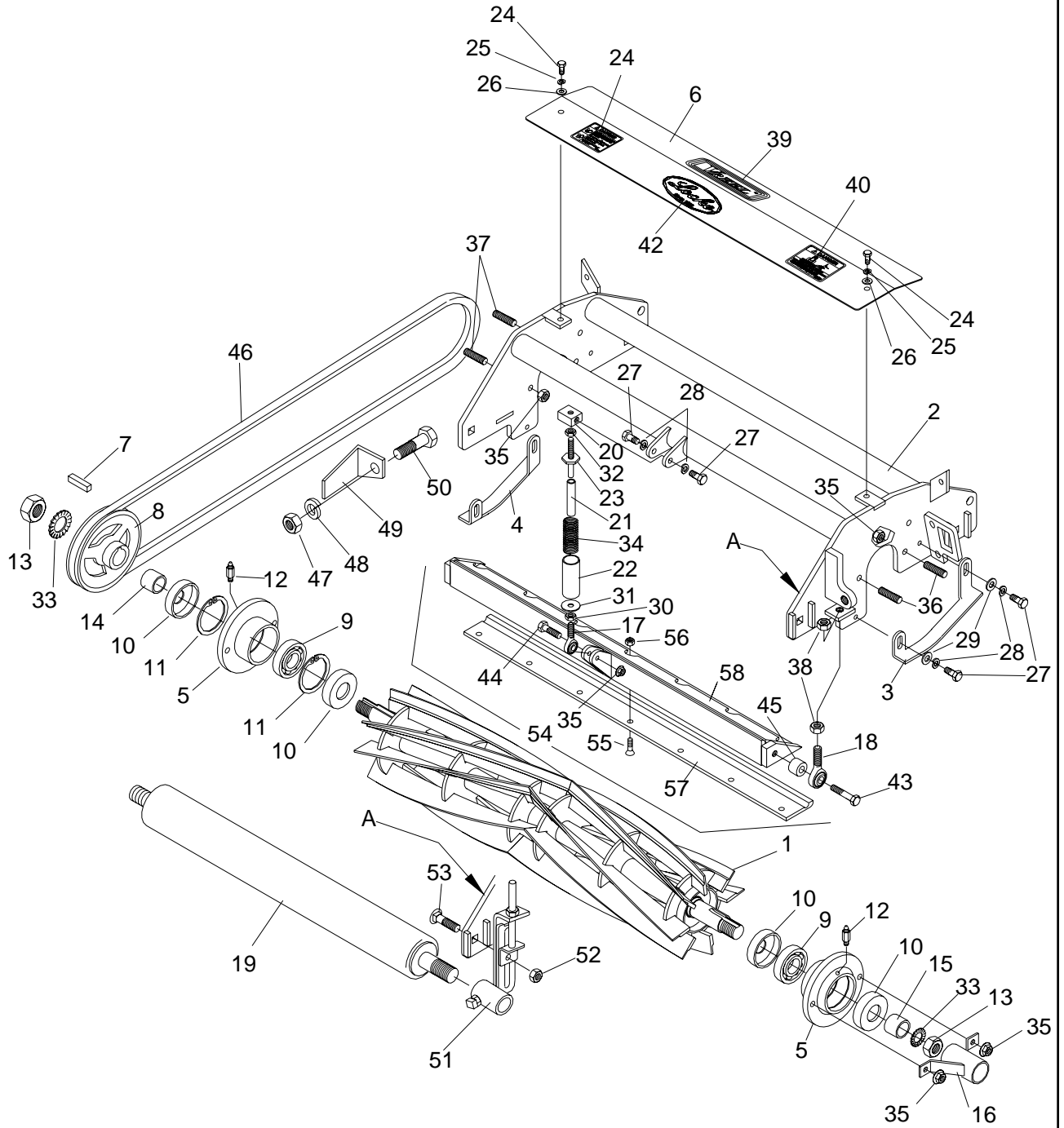

Cutting Unit V-Reel

REF. NO.	PART NO.	QTY	DESCRIPTION	REF. NO.	PART NO.	QTY	DESCRIPTION
1	50035249	1	TRM-V Reel Weldment, 10 Blade	31	50035241	2	Washer, Fender .375 ID x 1.25 OD
	50035256	1	TRM-V Reel Weldment, 8 Blade				
2	50033911	1	TRM-V Reel Frame Weldment, #1	32	10151200	1	Jam Nut 3/8"-16 CP
	50033912	1	TRM-V Reel Frame Weldment, #2	33	44612	2	Star Lockwasher 3/4" Ext.
	50033916	1	TRM-V Reel Frame Weldment, #3	34	50023877	1	Spring, Compression
3	50033889	1	Skid Shoe, Left Hand	35	44621	9	Serrated Flange Hex Nut 3/8" CP
4	50033890	1	Skid Shoe, Right Hand				
5	50033885	2	Bearing Housing	36	44673	2	Set Screw 3/8" x 2" CP G8
6	50036105	1	Top Shield, TRM-V Reel #1	37	44889	2	Set Screw 3/8" x 1-1/2" CP G8
	50036106	1	Top Shield, TRM-V Reel #2,3				
7	93810	1	Key, 1/4" sq. x 1"	38	44608	4	Jam Nut 1/2" CP NF
8	50019951	1	Sheave. 7/8" Bore x 4.40 PD	39	50030140	1	V-Reel Decal
9	50022189	2	Bearing, Reel	40	50022075	1	Danger Decal
10	50022187	4	Oil Seal	41	50022077	1	Danger Decal
11	50022185	2	Retaining Ring	42	500034	1	Locke Decal
12	50022184	2	Grease Fitting, 1/4"-28 (Extended)	43	20110	2	HHCS 1/2" x 2" G5 ZP
13	44606	2	Jam Nut 3/4" NF CP	44	20881	1	HHCS 3/8" x 1-1/2" G5 ZP
14	50022121	1	Spacer, Drive Side	45	50036135	2	Bed Bar Spacer
15	50022124	1	Spacer, Reel End	46	50022097	1	Belt - V B64 Reel Drive
16	50022133	1	Safety Cup Weldment	47	8151400	1	Hex Nut 7/16"-14 G5
17	50025702	1	Rod End, 3/8"-24 Male Right Hand	48	15819	1	Lockwasher 7/16"
18	50035220	2	Rod End, High Strength 1/2"-20 Male Right Hand	49	50022125	1	Pulley Scraper, RH (#1,2,4)
					50022126	1	Pulley Scraper, LH (#3,5)
19	50022191	1	Smooth Roller Assembly	50	1161416	1	HHCS 7/16"-14 x 1-3/4" Single Roller
	50022202	1	Grooved Roller Assembly				
20	50033906	1	Trunion		44614	1	HHCS 7/16"-14 x 1-1/4" Double Roller
21	50033903	1	Adjuster Inner Tube				
22	50033904	1	Spacer Tube	51	50022154	1	Roller Bracket Assy. LH (1 & 2 Roller)
23	50033909	1	Adjuster Screw Weldment				
24	1141006	2	HHCS 5/16" x 3/4"		50022156	1	Roller Bracket Assy. RH (1 & 2 Roller)
25	15808	2	Lockwasher 5/16" CP				
26	15907	2	Flatwasher 5/16" USS CP	52	44539	2	Hex Nut, Nylock 1/2"-13
27	19100	6	HHCS 3/8" x 3/4" CP G5	53	5161614	2	Carriage Bolt 1/2"-13 x 1-1/2"
28	15812	6	Lockwasher 3/8" CP	54	50036135	1	Bed Bar Assembly (55-58)
29	15830	4	Flatwasher 3/8" SAE CP	55	44552	7	Flat Head Screw 5/16" x 1"
30	15597	1	Hex Nut 3/8" NF CP	56	44553	7	Hex Nut 5/16" CP Nylock
				57	50022134	1	Bedknife
				58	50033880	1	Bed Bar

Double Roller Mowers

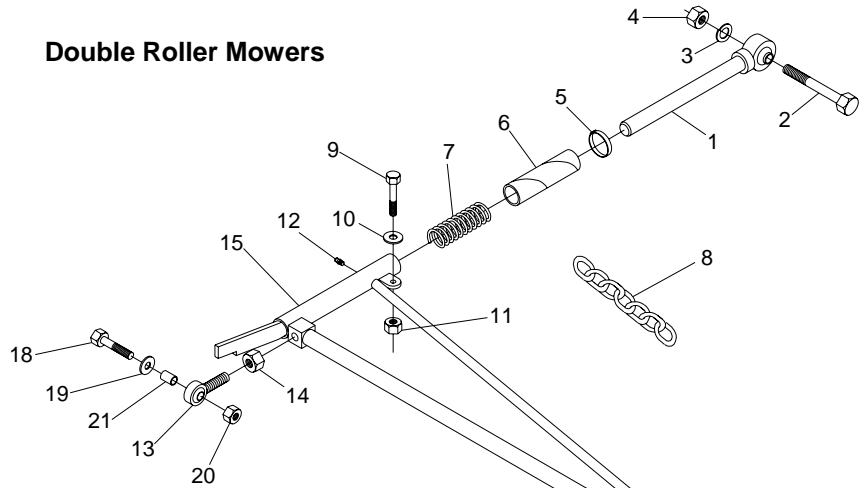

Stabilizer Arm and Telescoping Arm

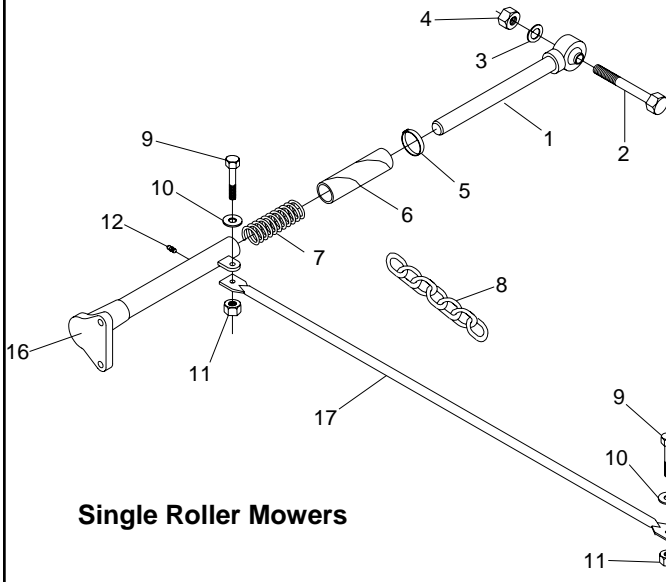

Single Roller Mowers

REF. NO.	PART NO.	QTY	DESCRIPTION
1	50022130	1	Telescoping Arm, Shaft Assy.
2	50022123	1	Pivot Bolt 3/4"-10
3	146	1	Lockwasher 3/4"
4	19517	1	Hex Nut 3/4"-10
5	50022068	1	Pinch Clamp 1-23/32" x 1-25/32"
6	50019665	1	Telescoping Arm Sleeve
7	50022069	1	Telescoping Arm Spring
8	50022142	1	Chain, Safety
9	20011	2	HHCS 5/16"-18 x 1-1/2" G5
10	20568	1	Flatwasher 5/16"
11	15528	1	Hex Nut 5/16"-18
12	449	1	Grease Fitting 1/4"-28
13	500199870	2	Rod End RH 5/8"-18
14	15653	2	Jam Nut 5/8"-18
15	50022193	1	Stabilizer Arm RH (Dbl Roller)
	50022164	1	Stabilizer Arm LH (Dbl Roller)
16	50022198	1	Telescoping Arm, Single Roller
17	50022199	1	Telescoping Arm, Stay Rod
18	20110	2	HHCS 1/2"-13 x 2 G5
19	15829	A/R	Flatwasher 1/2"
20	44539	2	Hex Nut Nylock 1/2"-13
21	50022484	2	Pivot Bushing (Dbl. Roller)

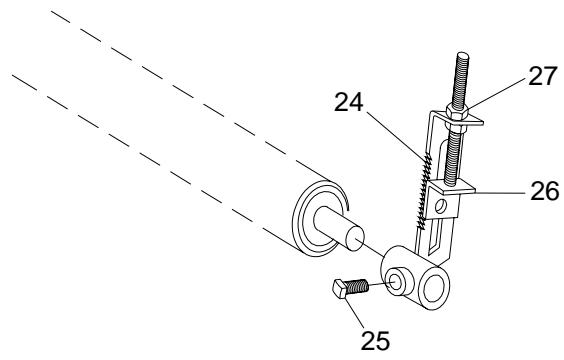

Rollers and Roller Brackets

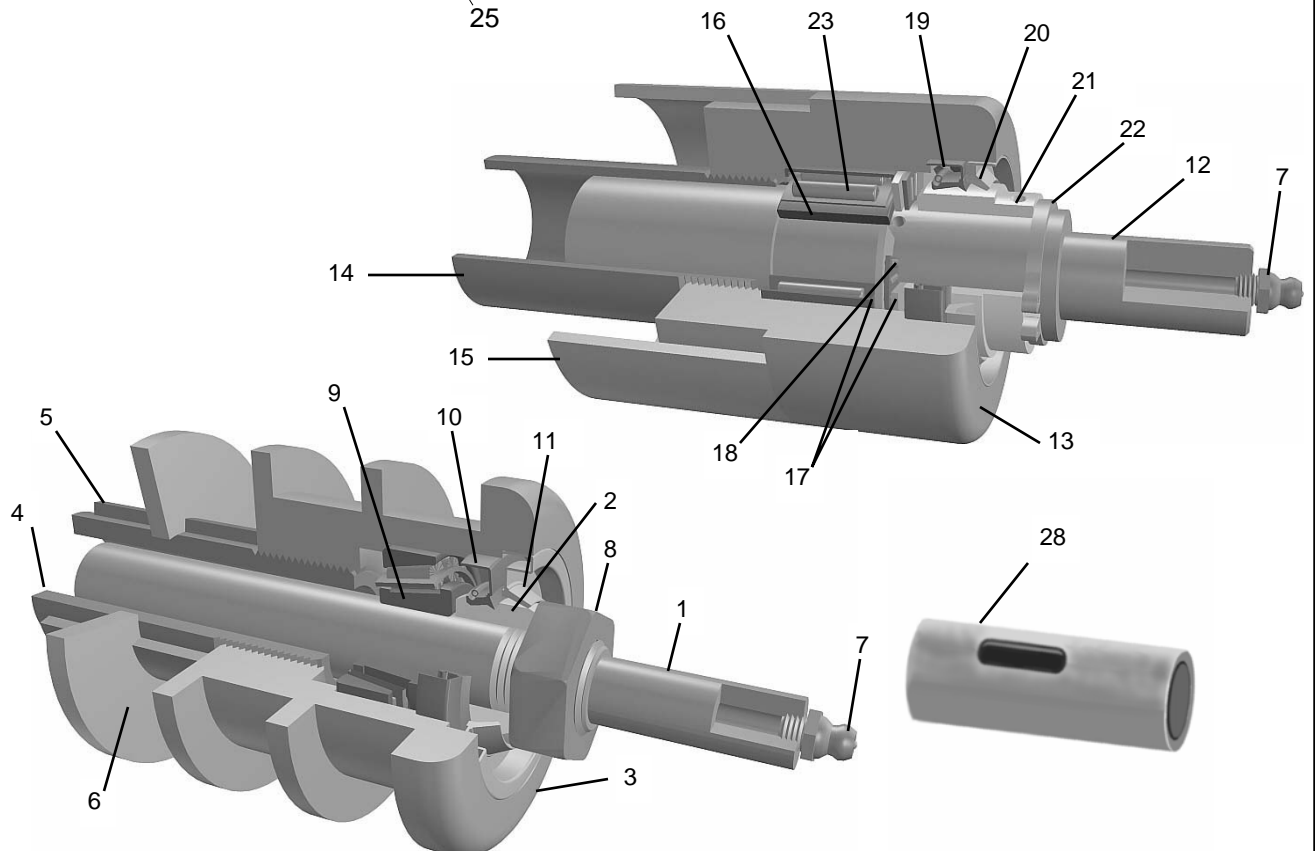

REF. NO.	PART NO.	QTY	DESCRIPTION
1	50022596	1	Roller Shaft, Grooved Roller
2	50022597	2	Wear Sleeve
3	50022598	2	Roller, End Grooved Roller
4	50022599	1	Inner Tube, Grooved Roller
5	50022600	A/R	Spacer
6	50022601	A/R	Washer
7	449	2	Grease Fitting
8	44606	2	Jam Nut, 3/4"-16
9	50022602	2	Bearing Set
10	50022603	2	Grease Set
11	50022604	2	Dust Set
12	50022605	1	Roller Shaft, Smooth Roller
13	50022607	2	Roller End, Smooth Roller
14	50022608	1	Inner Tube
15	50022609	1	Outer Tube
16	50022610	2	Bearing Inner Race
17	50022611	4	Thrust Bearing Race

REF. NO.	PART NO.	QTY	DESCRIPTION
18	50022612	2	Thrust Bearing
19	50022613	2	Grease Seal, Smooth Roller
20	50022614	2	Dust Seal, Smooth Roller
21	50022606	2	Wear Sleeve, Smooth Roller
22	50022615	2	Retaining Ring
23	50022616	2	Bearing, Needle
24	50022155	1	Roller Bracket, RH
	50022150	1	Roller Bracket, LH
25	18141206	2	Set Screw 3/8"-16 x 3/4"
26	50022153	2	Roller Bracket Adjuster
27	8151200	4	Hex Nut 3/8"-16
28	50022203	2	Adapter Bushing

Track Brush

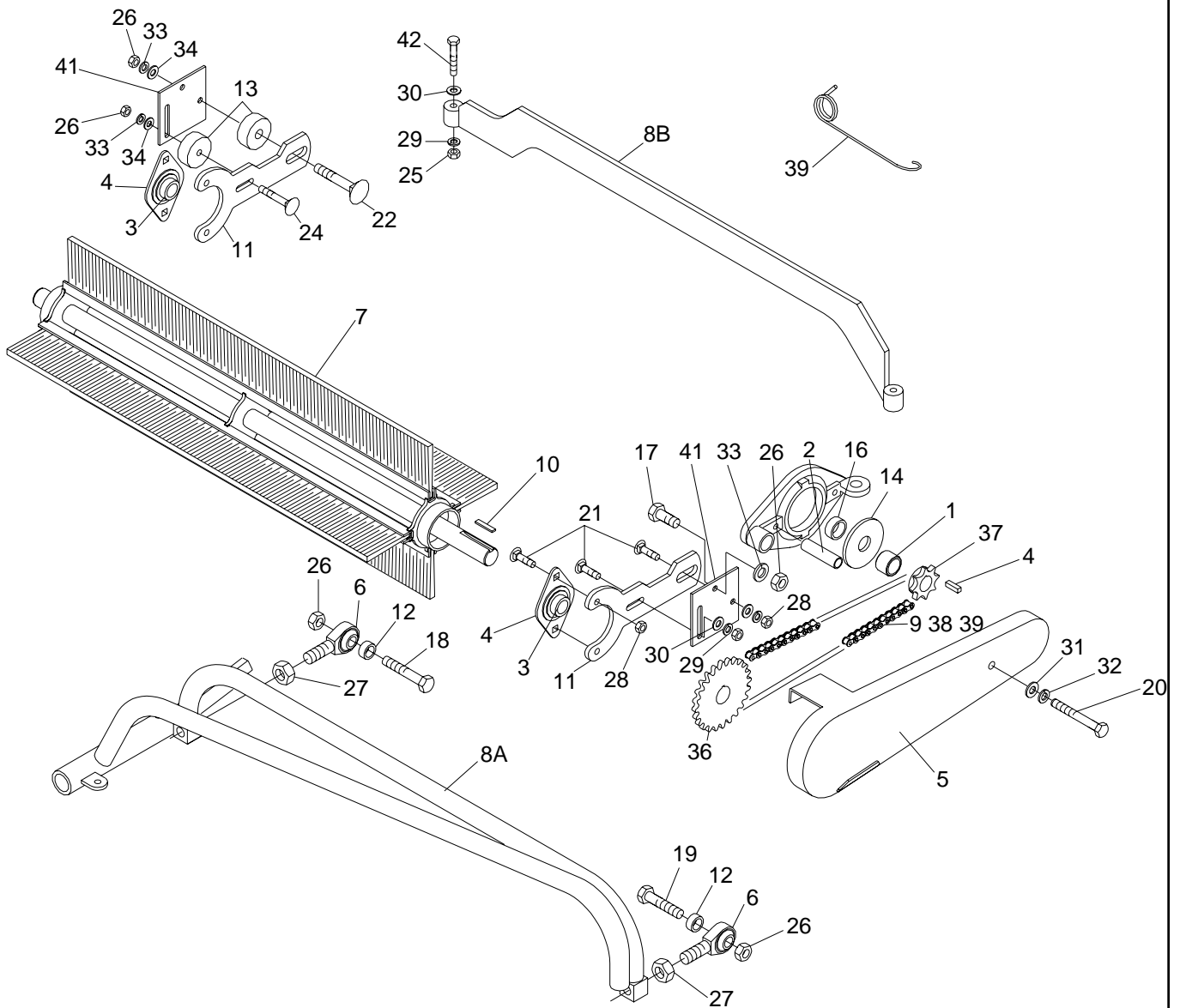

Track Brush

REF. NO.	PART NO.	QTY	DESCRIPTION
1	50022121	1	Spacer - Drive Side
2	50022437	1	Spacer
3	50022468	2	Bearing 1"
4	50022439	1	Step Key 3/16" x 1/4" x 13/16"
5	50022442	1	Chain Guard RH (Not Shown)
	50022467	1	Chain Guard LH (Shown)
6	50019870	2	Rod End 5/8" Bore RH Thread
7	50022449	1	Brush Assy.
8A	50022465	1	Stabilizer Arm for RH Double Roller (Not Shown)
	50022466	1	Stabilizer Arm for LH Double Roller (Shown)
8B	50022473	1	Stay Rod Weld. (Single Roller)
9	50022501	1	Roller Chain #40
10	19455	1	Key, Square 1/4" x 7/8"
11	50022453	2	Side Plate
12	50019875	2	Spacer, Tie Rod
13	50022455	1	Spacer
14	50022456	1	Shield Disc
15	50022457	1	Spacer
16	50022458	1	Spacer
17	44094	2	HHCS 1/2" x 1-1/4" Gr5
18	20110	1	HHCS 1/2" x 2" Gr5
19	19065	1	HHCS 1/2" x 2-1/2" Gr5
20	44619	1	HHCS 3/8" x 3-1/4" Gr5
21	44319	5	Carriage Bolt 5/16" x 1" Gr5
22	44620	1	Carriage Bolt 1/2" x 2-1/2" Gr5
23	44181	1	HHCS 3/8" x 1-1/2" Gr8
24	44289	1	Carriage Bolt 1/2" x 2-1/2" Gr5
25	15528	2	Hex Nut 5/16"
26	8151600	4	Hex Nut 1/2"
27	15509	2	Hex Nut 5/8"
28	44553	4	Hex Nut, Nylock 5/16"
29	15808	4	Lockwasher 5/16"
30	15901	2	Flatwasher 5/16"
31	15830	1	Flatwasher 3/8"
32	15812	1	Lockwasher 3/8"
33	15806	4	Lockwasher 1/2"
34	15916	2	Flatwasher 1/2"
35	50022459	4	Compensator Spring
36	50022400	1	Sprocket 40B24 - 1" Bore
37	50022461	1	Sprocket 40B11- 7/8" Bore
38	50022462	1	Connector Link
39	50019860	1	Master Link #40
40	0461099	4	Flangette
41	50023545	2	Mount Bracket
42	1161020	2	HHCS 5-16" x 2" Gr5

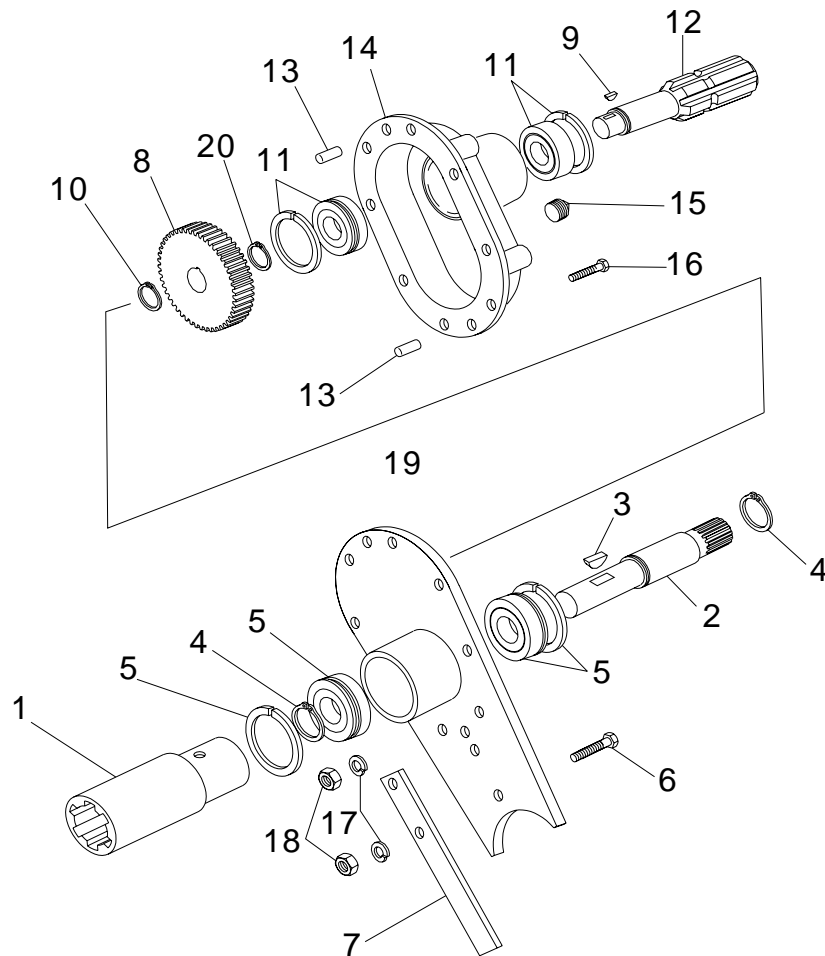

50019543 Backlapper Assembly

REF. NO.	PART NO.	QTY	DESCRIPTION
1	50022170	1	Coupling - Pump 1-3/8" 6 Spl x 1" Bore
2	50022171	1	Tractor Mt. Backlapper Input Shaft
3	50026279	1	Woodruff Key #808 1/4" x 1"
4	50022173	1	Snap Ring Ext 5100-118 1.188 Shaft
5	50022173	1	Bearing 6006-22RSNR 30 x 55 x 13mm
6	19114	2	HHCS 1/4"-20 x 1-1/4" Gr5
7	50022174	1	Stop, Tractor Drawbar
8	50022300	1	Gear (45 Tooth)
9	20593	1	Woodruff Key #606 3/16" x 3/4"
10	50022291	1	Snap Ring Ext. .875 Shaft
11	50022292	2	Bearing 6205-2RS1NR 25 x 52 x 15mm
12	50022293	1	Output Shaft
13	44613	2	Dowel Pin 1/4"OD x 1/2" Long
14	50022295	1	Backlapper Case
15	50022296	1	Plug 1/2" NPT
16	44186	8	HHCS 1/4"-20 x 1" Gr5
17	15918	8	Flatwasher 1/4" SAE
18	44566	8	Hex Nut Nylock 1/4"-20
19	50022299	1	Backlapper Case Cover
20	50022326	1	Snap Ring Ext. .984

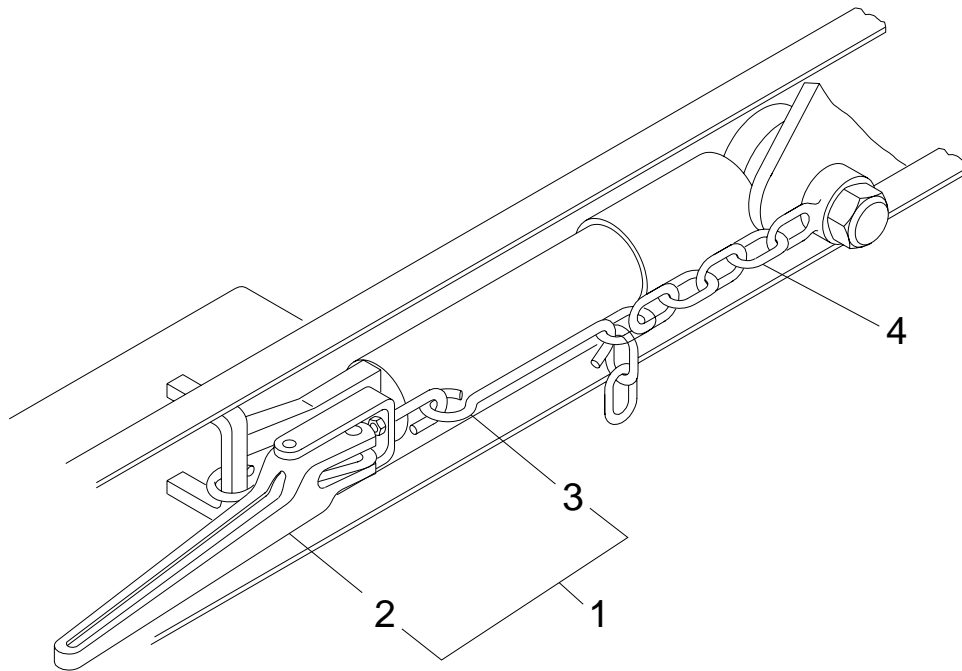

50026864 Chain and Binder Kit

REF. NO.	PART NO.	QTY	DESCRIPTION
1	50019919	1	Binder Assembly
2		1	Load Binder
3		1	Hook
4	50022010	1	Chain Weldment

50022333 Decal Kit TRM-3083

Part No.	Qty No.	Description
	2	Model Decal (TRM 3083)
50022064	1	Caution Decal (540 RPM, Gearbox)
50022065	1	Danger Decal (PTO Shield)
500033	5	Locke Decal
50022066	2	Danger Decal (Tongue)
50022067	2	Decal, Flag (Tongue)
50022070	1	Warning Decal (Tongue)
50022071	1	Warning Decal (Tongue)
50022072	1	Danger Decal (PTO Shield)
50022073	1	Warning Decal (Tongue)
50022074	1	Notice Decal (PTO Shield)
50022075	6	Danger Decal (Reel Head Shield)
50022076	4	Caution Decal (Frame & Tire)
50022077	10	Danger Decal (Frame & Tire)
50022079	1	Caution Decal (Cylinder)
50022081	1	Notice Decal (Tongue)
50022303	4	Caution Decal (Frame & Tire)
50031214	4	Red Reflector
53315	4	Amber Reflector



500033



50022064

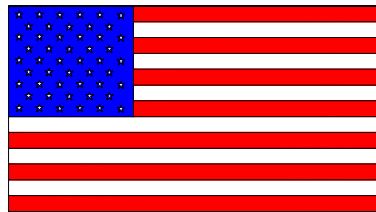

50022067



50022065



50022066



50022075



50022070



50022081

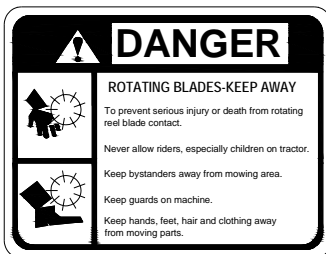

50022077

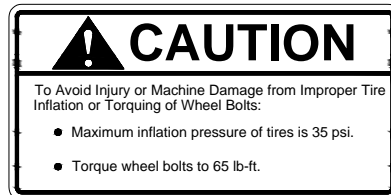

50022303

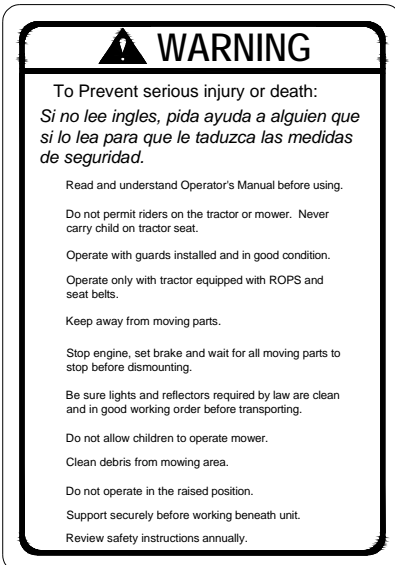

50022073

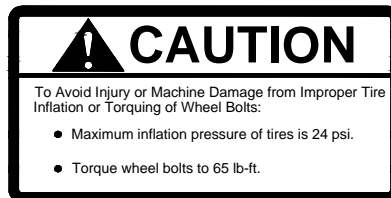

50022076



50022074

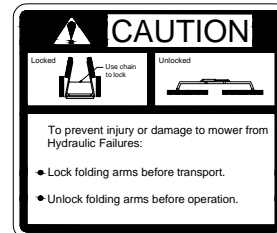

50022079



50022072



Amber Reflector 53315



Red Reflector 53316

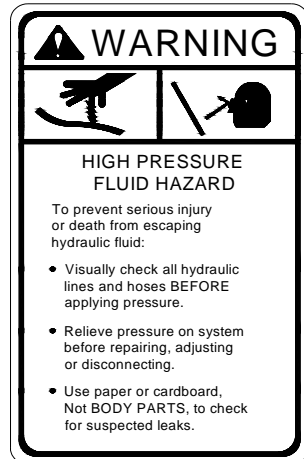

50022071



Locke Turf

307 Highway 52E, Opp, Alabama 36467, (334) 493-1300