



# Reel Mower TRM-3083, TRM-5138 TRM-7192



## Operators Manual

Locke Turf  
307 Highway 52E, Opp, Alabama, 36467, (334) 493-1300

# CONGRATULATIONS

You have invested in the best implement of its type on the market today.

The care you give your Locke Turf implement will greatly determine your satisfaction with its performance and its service life. We urge a careful study of this manual to provide you with a thorough understanding of your new implement before operating, as well as suggestions for operation and maintenance.

If your manual should become lost or destroyed, Locke Turf will be glad to provide you with a new copy. Order from Locke Turf, 307 Highway 52E, Opp, Alabama 36467.

As an Authorized Locke Turf dealer, we stock genuine Locke Turf parts which are manufactured with the same precision and skill as our original equipment. Our trained service personnel are well informed on methods required to service Locke Turf equipment, and are ready and able to help you.

Should you require additional information or assistance, please contact us.

YOUR AUTHORIZED  
LOCKE TURF DEALER

BECAUSE LOCKE TURF MAINTAINS AN ONGOING PROGRAM OF PRODUCT IMPROVEMENT, WE RESERVE THE RIGHT TO MAKE IMPROVEMENTS IN DESIGN OR CHANGES IN SPECIFICATIONS WITHOUT INCURRING ANY OBLIGATION TO INSTALL THEM ON UNITS PREVIOUSLY SOLD.

BECAUSE OF THE POSSIBILITY THAT SOME PHOTOGRAPHS IN THIS MANUAL WERE TAKEN OF PROTOTYPE MODELS, PRODUCTION MODELS MAY VARY IN SOME DETAIL. IN ADDITION, SOME PHOTOGRAPHS MAY SHOW SHIELDS REMOVED FOR PURPOSES OF CLARITY. **NEVER OPERATE** THIS IMPLEMENT WITHOUT ALL SHIELDS IN PLACE.

# REEL MOWER

# Operator's Manual

## Table of Contents

### SECTION

Introduction .....	2,3	Lift Chain Adjustment.....	8
Federal Laws and Regulations .....	4	Mowing Unit Belt Adjustment.....	8
Dealer Preparation Check List.....	5	Mowing.....	9
Federal Laws and Regulations.....	7	Reel Adjustment.....	9
Safety.....	7	Mowing Height Adjustment.....	10
Operation.....	7	Hydraulic Lift Operation.....	11
Hook Up.....	7	Mowing w/ V-Reel.....	12
Leveling the Frame.....	7	Trouble Shooting.....	15
Tractor Hook-Up.....	8	Maintenance.....	16
Belt Idlers.....	8	Component Location Diagrams.....	17
		Safety Decals.....	18
		Torque Specifications.....	21

## RETAIL CUSTOMER'S RESPONSIBILITY

### UNDER THE LOCKE TURF INC. WARRANTY

It is the Retail Customer and /or Operator's responsibility to read the Operator's Manual, to operate, lubricate, maintain, and store the product in accordance with all instructions and safety procedures. Failure of the operator to read the Operator's Manual is a misuse of this equipment.

It is the Retail Customer and/or Operator's responsibility to inspect the product and to have any part(s) repaired or replaced when continued operation would cause damage or excessive wear to other parts or cause a safety hazard.

It is the Retail Customer's responsibility to deliver the product to the authorized Locke Turf distributor from whom he purchased it, for service or replacement of defective parts that are covered by warranty. Repairs to be submitted for warranty consideration must be made within fort-five (45) days of failure.

It is the Retail Customer's responsibility for any cost incurred by the Dealer for traveling to or hauling of the product for the purpose of performing a warranty obligation or inspection.

### UNDERSTAND SIGNAL WORDS

**DANGER:** Indicates an imminently Hazardous situation which, if not avoided, will result in death or serious injury. This signal word is to be limited to the Most extreme situations.

**WARNING:** Indicates a potentially hazardous situation which, if not Avoided, could result in death or serious injury.

**CAUTION:** Indicates a potentially hazardous situation which, if not avoided, may result in minor or Moderate injury. It may also be Used to alert against unsafe

## INTRODUCTION

More than merely devices created for mowing grass, the excellence of design, construction and operation of Locke power mowers is unparalleled. Introduced in 1928, tested and proven, Locke power mowers may be considered, in terms of today's technology, the ultimate response to the need for the highest degree of quality lawn care. These magnificent green machines are legendary and known throughout the world for generation-spanning durability and unequalled performance in the precision cutting of grass.

Locke power mowers are heavy-duty, precision instruments. No capricious model year or cosmetic style changes are instituted, although improvements are continually incorporated into all models. The most recent evidence this is in the introduction of the new "Commercial Series". Design and manufacturing innovations make this the mower for the next century. Whatever model of Locke power mower you have purchased you have our assurance that, with proper care, you are the owner of a machine which will provide many years of dependable service.

To extract the fullest possible value from the performance of your Locke power mower we urge you to read this manual very carefully. Should you find any of the instructions unclear, please contact your Locke dealer or call the Locke Factory Service Department.

Phone: 334-493-1300

Fax: 334-493-1400

*Locke Mowers: The Finest Cut....For The Finest Lawns*

# INTRODUCTION

Locke Turf welcomes you to the growing family of new product owners. This implement has been designed with care and built by skilled workers using quality materials. Proper assembly, maintenance and safe operating practices will help you get years of satisfactory use from the machine.

## Description of Unit

The TRM Model Reel Mowers are precision finishing implements. The placement and rotation of the cutting blades are installed to ensure the maximum "cut" without damaging the turf.

The Reel Mower is driven at a rate slower than PTO shaft to obtain maximum cut.

## Features Include:

- Drive ratio is factory preset to assure optimum cutting.
- Standard rear rollers and optional front rollers are mounted to maintain constant mowing height.
- Easy access for maintenance.
- Integral style hitch to implement prevents skewing on hillsides.
- Shields in place to prevent buildup.
- Mowing large areas of turf year after year with low maintenance.

## Intended Usage

This machine is intended to be used primarily for precision mowing of large areas of turf.

## Using This Manual

The Operator's Manual is designed to help familiarize you with safety, assembly, operation, adjustments, troubleshooting and maintenance. Read this manual and follow the recommendations to help ensure safe and efficient operation.

The information contained within this manual was current at the time of printing. Some parts may change slightly to assure you of the best performance.

## Terminology

"Right" or "Left" as used in this manual is determined by facing the direction the machine will travel while in use unless otherwise stated.

## Definitions:

**NOTE:** A special point of information related to its preceding topic. The author's intention is that you read and note this information before continuing.

**IMPORTANT:** Information, related to its preceding topic, that the author feels would be of use.

## Owner Assistance

If customer service or repair parts are required contact your local Locke Turf dealer. They have trained personnel, repair parts and the equipment needed to service your implement.

These parts have been specially designed and should only be replaced with genuine Locke Turf parts.

**Serial Number Plate** – Refer to Figure below for the location of your serial number plate.

Serial Number Plate Location

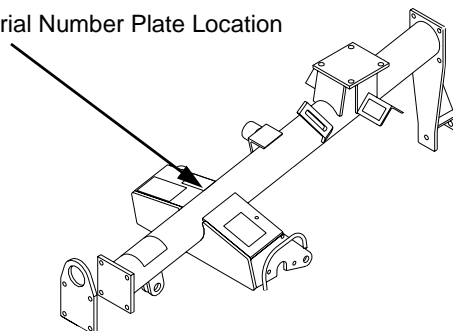

For prompt service always use the serial number and model number when ordering parts from your Locke Turf dealer. Be sure to include your serial number and model number in correspondence also.

Your dealer wants you to be satisfied with your new machine. If for any reason you are not satisfied with the service received, the following actions are suggested:

1. First, discuss the matter with your dealership service manager. Make sure they are aware of any problems you may have had and that they have had the opportunity to assist you.
2. If you are still not satisfied, seek out the owner or General Manager of the dealership and explain the problem and request assistance.
3. For further assistance beyond that provided by your dealer, you may contact:

Locke Turf – Customer Service  
307 Highway 52E  
Opp, Alabama 36467

# DEALER PREPARATION CHECK LIST

## REEL MOWER

BEFORE DELIVERING MACHINE- The following check list should be completed. Use the Operator's Manual as a guide.

- 1. Assembly completed.
- 2. Gearbox filled with oil.
- 3. All fittings lubricated.
- 4. All shields in place and in good condition.
- 5. All fasteners torqued to specifications given in Torque Chart.
- 6. All decals in place and readable. (See decal page.)
- 7. Overall condition good (i.e. paint, welds)
- 8. Operators manual has been delivered to owner and he has been instructed on the safe and proper use of the mower.

Dealer's Signature \_\_\_\_\_

Purchaser's Signature \_\_\_\_\_

THIS CHECKLIST IS TO REMAIN IN OWNER'S MANUAL  
It is the responsibility of the dealer to complete the procedures listed above before delivery of this implement to the customer.

# IMPORTANT FEDERAL LAWS AND REGULATIONS\* CONCERNING EMPLOYERS, EMPLOYEES AND OPERATIONS.

\*(This section is intended to explain in broad terms the concept and effect of the following federal laws and regulations. It is not intended as a legal interpretation of the laws and should not be considered as such.)

U.S. Public Law 91-596 (The Williams-Steiger Occupational and Health Act of 1970) OSHA

## **This Act Seeks:**

"...to assure so far as possible every working man and woman in the nation safe and healthful working conditions and to preserve our human resources..."

## **DUTIES**

Sec. 5 (a) Each employer-

- (1) shall furnish to each of his employees employment and a place of employment which are free from recognized hazard that are causing or are likely to cause death or serious physical harm to his employees;
- (2) shall comply with occupational safety and health standards promulgated under this Act.
  - a. Each employee shall comply with occupational safety and health standards and all rules, regulations and orders issued pursuant to this Act which are applicable to his own actions and conduct.

## **OSHA Regulations**

Current OSHA regulations state in part: "At the time of initial assignment and at least annually thereafter, the employer shall instruct every employee in the safe operation and servicing of all equipment with which the employee is or will be involved." These will include (but are not limited to) instructions to:

Keep all guards in place when the machine is in operations:

Permit no riders on equipment;

Stop engine, disconnect the power source and wait for all machine movement to stop before servicing, adjusting, cleaning or unclogging the equipment, except where the machine must be running to be properly serviced or maintained, in which case the employer shall instruct employees as to all steps and procedures which are necessary to safely service or maintain the equipment.

Make sure everyone is clear of machinery before starting the engine, engaging power or operating the machine.

## **EMPLOYEE TRACTOR OPERATING INSTRUCTIONS:**

1. Securely fasten your seat belt if the tractor has a ROPS
2. Where possible avoid operating the tractor near Ditches, embankments and holes.
3. Reduce speed when turning, crossing slopes and on rough, slick or muddy surfaces
4. Stay off slopes too steep for safe operation
5. Watch where you are going especially at row ends, on roads and around trees.
6. Do not permit others to ride.
7. Operate the tractor smoothly – jerky turns starts or stops
8. Hitch only to the drawbar and hitch points recommended by tractor manufacturers
9. When tractor is stopped, set brake securely and use park lock if available

## **Child Labor Under 16 Years Old**

Some regulations specify that no one under the age of 16 (sixteen) may operate power machinery. It is your responsibility to know what these regulations are in your own area or situation. (Refer to U.S. Dept. of Labor, Employment Standard Administration, Wage & Home Division, Child Labor Bulletin #102.)

## SECTION 1 – SAFETY

### IMPORTANT SAFETY INFORMATION

This Safety Alert Symbol means:



**ATTENTION! BECOME ALERT!  
YOUR SAFETY IS INVOLVED!**

The Safety Alert Symbol identifies important safety messages in manuals and on equipment safety signs. To avoid possible injury or death, follow the equipment and manual's safety instructions.

In addition to the design and configuration of equipment, hazard control and accident prevention are dependent upon the awareness, concern, prudence and proper training of personnel in the operation, transport, maintenance and storage of equipment.

Read the operator's manual for your safety and understanding of the equipment. Store the manuals in a safe and accessible location for your future reference.

#### Safety Rules

Following the safety practices in the operator's manuals and equipment safety signs will help minimize accident possibility and increase equipment productivity.

**MAKE SURE EVERYONE THAT WILL USE THIS MACHINE HAS READ OR HAD THE OPERATOR'S MANUAL AND EQUIPMENT SAFETY SIGNS INFORMATION EXPLAINED AND UNDERSTANDS HOW TO OPERATE IT SAFELY.**

#### General

The safe operation of any machinery is a big concern to users and manufacturers. Your Verti-Cutter has been designed with many built-in safety features. However, no one should operate this machine before carefully reading the Operator's Manual.

1. Do not allow anyone to operate this machine that has not been properly trained in its safe operation.
2. Do not let children operate the implement.
3. Never allow passengers.
4. Never operate the mower near people; and maintain as much distance from the rear of the mower and any people as possible.
5. Before mowing, clear the area of objects and debris that could become entangled in the blades or thrown from the mower.
6. After striking an object, disengage PTO, shut off tractor and inspect for damage before continuing.
7. Do not operate the cutter in reverse unless necessary. Check periodically for loose hardware

- and tighten if necessary.
8. Travel slowly over rough terrain and be alert to holes and gullies
9. When traveling on public roads, use accessory lights and devices for adequate warning to operators of other vehicles. Comply with all Federal, State and Local laws.
10. Never operate the Reel Mower while in the raised transport position.
11. Be alert to traffic when crossing or cutting near roadways.
12. Disengage the tractors' PTO when raised transport.
13. Wear proper eye protection to prevent injury from flying objects.
14. Keep PTO shielding in place and in good condition. Do not operate mower with shields missing.
15. Always use proper PTO speed or machine damage may result. This mower is designed to be used with a tractor using a 540 rpm rear PTO. **Important: never should a tractor equipped with a 1000 rpm PTO operate a machine equipped for 540 rpm PTO.**
16. In order to maintain steering control add ballast to tractor. To determine the amount of ballast required refer to your tractor operator's manual.
17. Before performing maintenance, disconnect PTO driveline and hydraulic hoses and make sure the transport locks are installed on the wing decks and center deck.
18. Transport mower with transport chain in place.
19. Escaping hydraulic fluid under pressure can have sufficient force to penetrate the skin. Check all hydraulic hoses before applying pressure. Fluid escaping from a very small hole can be almost invisible. Use a piece of cardboard, not body parts, to check for suspected leaks. If injured, seek medical assistance from a doctor that is familiar with this type of injury. Foreign fluids in the tissue must be surgically removed within a few hours or gangrene will result.
20. Do not permit anyone to stand between tractor and mower – especially during tractor hook-up.
21. Stand clear of mower when raising or lowering.

#### Prior To Operation

1. Do not stand between tractor and implement during hitching.
2. Do not operate without safety chain properly attached to tractor.
3. Make sure hydraulic lines are attached to correct ports.



**SOME ILLUSTRATIONS MAY SHOW SHIELDS OR COVER PANELS REMOVED FOR CLARITY. NEVER OPERATE UNIT WITHOUT ALL SHIELDS AND COVER PANELS IN PLACE.**



## During Operation

1. Tractor should be equipped with ROPS and seat belt during operation.
2. Do not allow anyone to operate this machine who has not been properly trained in its safe operation.
3. Do not allow children to operate the implement.
4. Never dismount from a moving tractor.
5. Put tractor in park, turn off engine, remove key and allow moving parts to stop before making any adjustment to the implement.
6. Do not leave the tractor or the implement with the engine running.
7. Never allow passengers.
8. Travel slowly over rough terrain and be alert to holes and gullies.
9. Loose fitting clothing should not be worn as it may catch in moving parts.
10. If a hydraulic leak develops, correct it immediately. Escaping hydraulic oil can have extremely high pressure. A stream of high-pressure oil may easily penetrate the skin as with modern needle less vaccination equipment, but with the exception that hydraulic fluid may cause blood poisoning. It is imperative that the connections are tight and that all lines and pipes are in good condition. If the escaping hydraulic fluid causes an injury, see a doctor at once! Use a piece of cardboard or wood to detect leaks of hydraulic oil under pressure. Be sure to relieve all hydraulic pressure before disconnecting any lines or pipes between the implement and the tractor hydraulic system. Keep all guards and shields in place.
11. Do not turn tractor in too tight; implement may ride up on wheels causing machine and bodily damage.



### **WARNING**

**CONTACT WITH OVERHEAD POWER LINES CAN CAUSE SEVERE ELECTRICAL BURNS OR DEATH FROM ELECTROCUTION. MAKE SURE THERE IS ENOUGH CLEARANCE BETWEEN COMPONENTS AND OVERHEAD POWER LINES. DO NOT LOAD NEAR POWER LINES. DO NOT CLIMB NEAR POWER LINES.**



### **WARNING**

**THIS MACHINERY CAN BE VERY DANGEROUS AND CAN CAUSE SEVERE INJURY OR DEATH BY ENTANGLEMENT. READ AND UNDERSTAND MANUAL BEFORE ATTEMPTING TO OPERATE IT.**

## After Operation

1. Detach and store implement in an area where children normally do not play. Stabilize implement by using suitable supports and block wheels.
2. Be alert to traffic when crossing or operating near roadways. Always maintain complete control of the machine. Know your state and local laws concerning highway safety and regulations. Comply with these laws when transporting machinery.
3. Limit transport speed to 20 mph. Transport only with an appropriate vehicle of sufficient size and horsepower. Refer to Attaching Reel Mower to the tractor under the "Operating Instructions" section.

## During Maintenance

1. Securely block up implement before doing any work underneath it.
2. Tire changing can be dangerous and should be performed by trained personnel using the correct tools and equipment.
3. Do not re-inflate a tire that has been run flat or seriously under inflated. Have it checked by qualified personnel.
4. When removing and installing wheels, use wheel handling equipment adequate for the weight involved.
5. Before greasing and oiling implement, shift tractor into park, disengage PTO, turn off engine, remove key and allow moving parts to stop.
6. After repairing or adjusting, make sure all tools and parts are removed from the implement before attempting to operate it.

### **NOTE**

**DURING BACKLAPPING OR SHARPENING, CAREFULLY FOLLOW THE INSTRUCTIONS THAT ARE FURNISHED WITH THE SHARPENING EQUIPMENT.**

## SECTION 2 – OPERATION

### Hook Up

1. Engage Clevis swivel hitch or ball hitch to tractor drawbar using draw bar pin or ball supplied.

#### IMPORTANT

**For correct leveling, adjust Reel Mower unit tongue height so that the front and rear jackshafts are equal distances above ground level.**

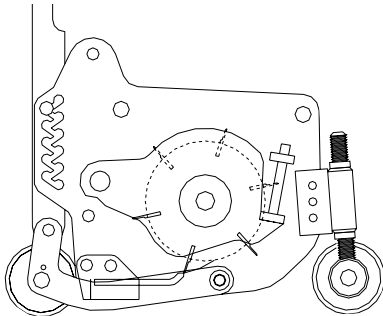

### Leveling the Frame – Tongue Adjustments

The bolt on section of the tongue can be rotated to three different positions. The clevis can be rotated two different ways. This provides 6 different heights for leveling the frame. (See diagram below)

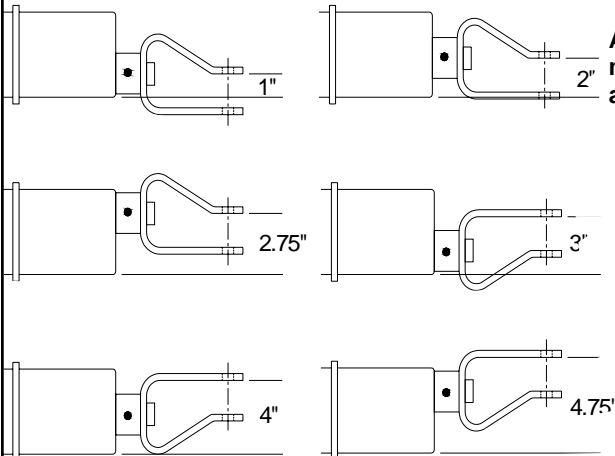

NOTE: The use of a drawbar hung between the 3-point hitch arms is not recommended; a straight drawbar attached to the rear axle housing in the standard SAE position to the PTO is preferable.

### Tractor Hook-Up

1. Back the tractor up close to the hitch. Raise or lower, with the hitch tongue jack, in order to level the mower's frame.

2. Adjust the mower's hitch to the tractor's drawbar height. Keep frame level, with tractor and mower on level ground. Place framing level across the square frame segments front to rear and adjust hitch height to level the frame.
3. Attach the mower with a 3/4" hitch pin and secure it with a lock pin. Always use a pin that contains a safety locking device to prevent it from falling out.
4. Lower the tongue jack until the weight of the mower is fully removed from the jack, then remove the jack. Store the jack on the left hand frame rail. A storage base is located on top of the frame tube.
5. Attach the safety chain on the frame hitch to the tractor. Adjust the chain length to remove all slack except what is necessary to permit turning of the mower. Lock the hook securely on the chain.
6. The driveline from the tractor is one with a constant velocity. Always attach the end with the constant velocity to the tractor's PTO shaft. Attach the other end to the splined jackshaft on the center of the transport frame.
7. Move the driveline back and forth to insure that it is secured on the PTO shaft of the tractor and power divider input shaft on the mower.
8. Secure the chain on the driveline around mower frame to restrict the outer shield of the driveline from rotating.

#### NOTE:

**A chain is supplied with each driveline. This chain must be attached to the shield cone of each driveline and to an anchor ring on the cutter hitch.**

9. Should the driveline shaft require shortening:
  - a. Hold the half shafts next to each other in the shortest working position and mark them.
  - b. Shorten inner and outer guard tubes equally.
  - c. Shorten inner and outer sliding profiles by the same length as the guard tubes.
  - d. Proper overlap is a minimum of one-half the length of each tube, with both tubes being of equal length.
  - e. Round off all sharp edges and remove burrs. Grease sliding profiles.
10. Route the cylinder hoses through the hose support and connect to tractor remote outlets. Refer to "Hydraulic Plumbing" on page 9 for proper hook-up. Quick disconnect hydraulic fittings for your tractor are available from your dealer.

### Hydraulic Hook-up

Insert the hydraulic hose quick-disconnect plugs into the female quick-disconnects on the tractor external hydraulics.

The large (constant velocity U-joint) end of the shaft goes on the tractor's PTO shaft.

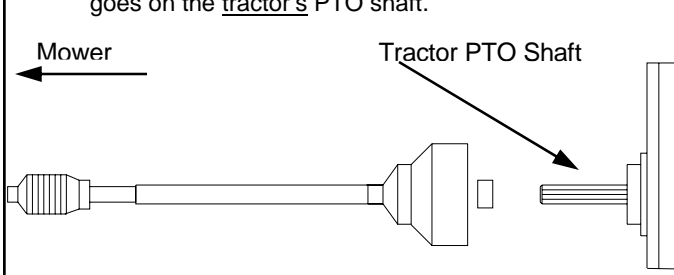

NOTE: Refer to page 16 for locations of components.

### Belt Idlers – Main Drive

Check regularly for correct belt tension, particularly every 5 to 10 hours following installation of new belts.

To adjust belt idlers:

1. Remove belt guards.
2. Loosen idler clamping bolt.
3. Adjust idler to allow 3/4" to 1" up and down movement of the bolt half way between sheaves.
4. Replace bolt guards.

### Lift Chain Adjustment - Units #4 & #5

The outer lift chains on mowing units #4 and #5 provide adjustment of the nylon rollers in the snubbers and lift operation. IF the #4 and #5 mowing units do not engage the snubber ramps properly when lifting, adjust as follows:

1. Lower cutting units to the ground and loosen the nut on the chain-adjusting rod and back off the nut several turns.
2. Remove the clevis pin from the adjusting yoke.
3. Turn the adjusting yoke towards the nut to increase the lift and decrease the roller clearance in the snubber.
4. Replace the yoke and clevis pin, making sure that the chain is not twisted.
5. Lift the mowing units into place to check that adjustment is correct when there is slight tension on the lift chain and the nylon rollers are tight in the snubber.
6. When adjustment is correct, tighten the adjusting rod locking nut. Insure also that the cotter pin is secure.

### Lift Chain Adjustment - Units #6 & #7

The inner chains on mowing units #6 and #7 allow adjustment for even lift. If the outer mowing units lift unevenly, they may be adjusted as follows:

1. Engage the lift valve slowly until the slack in the chains of the mowing unit which lifts first is removed.
2. Loosen the outer adjusting nut on the outer mowing unit inner chain.

3. Tighten the inner adjusting nut until all the slack is taken out of the chain.
4. Tighten the outer adjusting nut.

### Mowing Unit Drive Belt Replacement

To replace mowing unit drive belt:

1. Place mowing unit in mowing position.
2. Compress the telescoping arm using the belt release hook binder assembly from the tool box. Engage the belt release hook in the safety chain and the belt release lug as shown in the diagram. Close to compress the telescoping.
3. Remove the bolt holding the safety chain at the telescoping arm end.
4. Slip belt off reel pulley and disengage belt release hook.

**TELESCOPING ARM IS HEAVILY SPRUNG; EXTREME CARE MUST BE TAKEN TO AVOID PERSONAL INJURY.**

5. Remove small bolt on upper flange of V-belt guard.
6. Remove 3/4" bolt from telescoping arm end and guard.
7. To remove belt from center mowing units it is necessary to remove the coupling and pull the belt through the gap between the jackshafts.
8. Place the new belt around the jackshaft pulley, making sure that it goes to the right of a right hand telescoping arm or to the left of a left hand telescoping arm.
9. Replace the 3/4" bolt through the guard, telescoping arm and frame.
10. Replace the small bolt through the upper flange of the guard.
11. Replace the jackshaft coupling (if removed).
12. Compress the telescoping arm as in step 2.
13. Slip the belt on the reel pulley and disengage the belt release hook.
14. Attach the safety chain to the telescoping arm.

### Mowing Unit Drive Belt Replacement

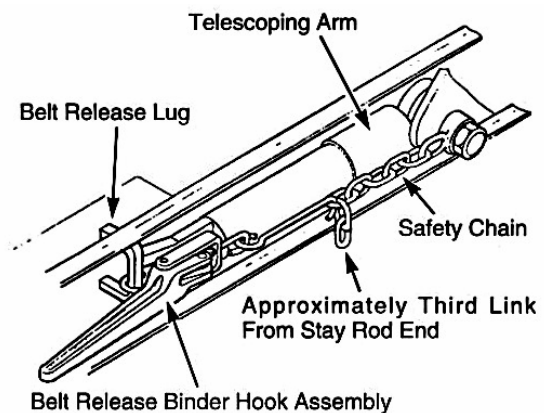

Lever shown with telescoping arm compressed relieving belt tension.

## Mowing

1. Lower the mowing units to the ground.
2. Engage the tractor PTO at low speed to avoid shock to the mower power train.
3. Select appropriate tractor gear range (maximum 5-1/2 mph or 8.8 km/h at rated PTO speed). Refer to Clip Ratio on page 11.
4. Accelerate to maximum PTO speed: 500-540 rpm.



**DO NOT ENGAGE THE PTO WITH MOWERS IN THE RAISED POSITION (TRANSPORT POSITION).**

**DO NOT RAISE THE MOWING UNITS WITH THE PTO ENGAGED.**

**MAKE SURE THE PTO IS DISENGAGED AND THE REELS HAVE STOPPED ROTATING BEFORE RAISING THE MOWING UNITS.**

Properly adjusted and sharpened mowing units will slice a sheet of writing paper as cleanly as a pair of scissors.

## Reel Adjustment

1. Compress the telescoping arm, using the belt release hook. Refer to "MOWING UNIT DRIVE BELT REPLACEMENT," Step 2. On units #6 & #7, secondary PTO must be disconnected at mowing unit for (by hand) reel adjustment.
2. Once the belt has been removed, loosen both adjusting screw lock bolts.
3. Back off the locking bolts JUST ENOUGH TO ALLOW the adjusting screws to be turned.
4. Rotate the adjusting screws.

### NOTE

To move the reel toward the bed knife—turn reel adjustment screw clockwise.

To move the reel away from the bed knife, turn reel adjustment screw counter—clockwise.

5. Slowly turn the reel by hand while inserting a double thickness of newsprint into the cutting edges of the mowing unit. A properly sharpened and adjusted reel will enable you to shear one thickness of the newsprint while only creasing the second thickness. This should be obtained along the entire length of the reel blades.

6. Retighten the locking bolts. **MAKE SURE THE ADJUSTING SCREWS ARE LOCKED SECURELY AND CANNOT ROTATE.**

### NOTE

**When adjusting reels by sound, a slight blade to blade contact noise will be heard once the adjustment has been made. This noise will increase until mower begins cutting grass.**

### IMPORTANT

**Do not operate mowing units with reel blades contacting the bed knife. Heavy metal to metal contact could lead to wear or damage which may require regrinding of the reel and bed knife.**

7. Once set, this adjusting mechanism is locked by the clamping action of the reel adjustment locking bolt.

## Reel Adjusting Mechanism

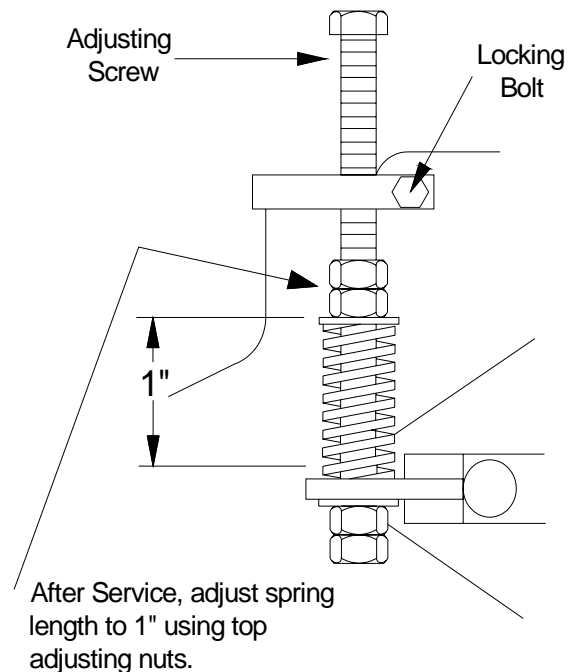

## Mowing Height Adjustment

To ensure the same height of cut on each mowing unit and that each unit is also cutting level, Adjustment Bar part no. 50019946 is available for making adjustments to height of cut.

REFER TO THE ILLUSTRATION BELOW (Place the mowing units in the transport position.)

1. Adjust the rear roller to minimum height by turning the adjuster (1) clockwise.
2. Adjust the front roller to minimum height by releasing locknut (2) and locknuts (3) and sliding the roller upwards.
3. Set the required height of cut on the adjusting bar front adjusting screw (4) as indicated by dimension "A."

4. Position the adjusting bar (5) as shown with the head of the front adjusting screw (4) resting on the bed knife (6). Tighten the rear adjusting screw (7) until it contacts the bed knife and are parallel.
5. Adjust the rear roller height of cut adjuster (1) by turning counter clockwise until the rear roller (9) contacts the adjusting bar (5).
6. Adjust the front roller (10) by sliding it down until it contacts the adjusting bar (5). Tighten the locknuts (3) and locknut (2).
7. Remove the adjusting bar assembly by releasing the rear adjusting screw (7).

### IMPORTANT

The above procedure must be carried out at both ends of the cutting unit to ensure an even height of cut across the cutting unit.

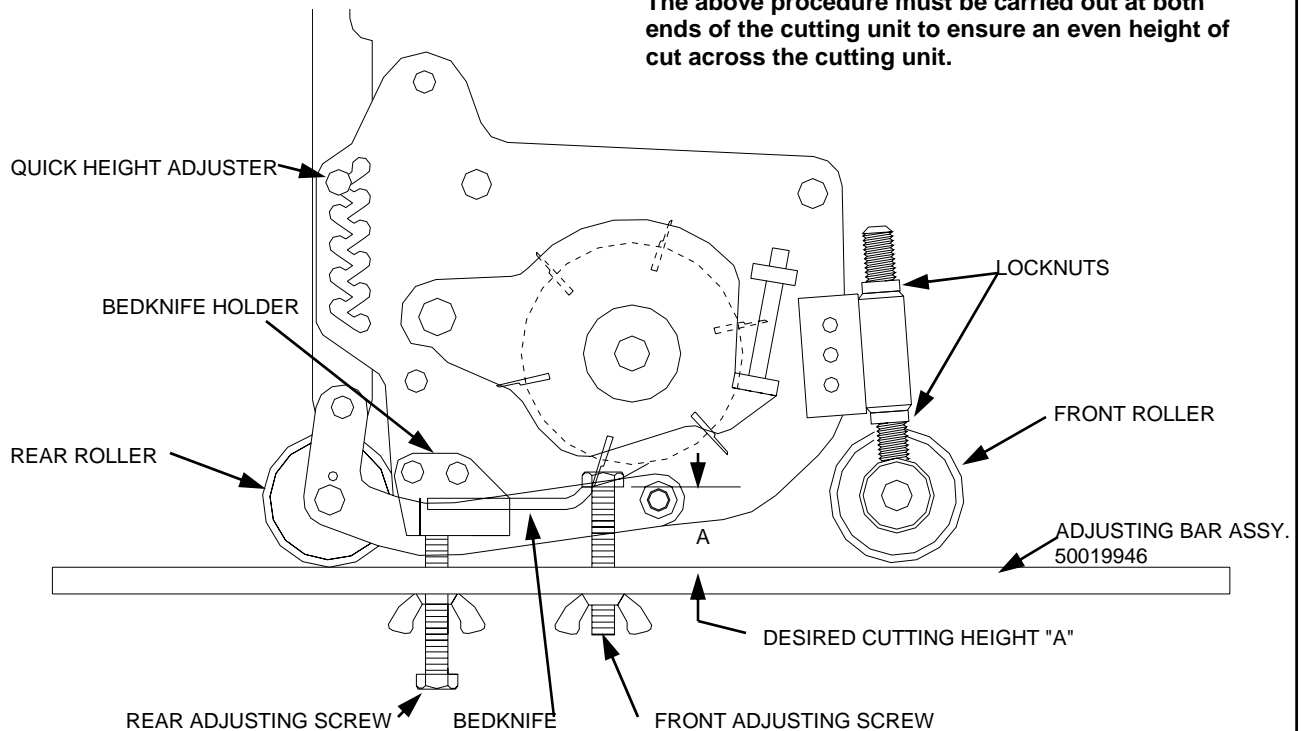

BLADES/REELS	TRACTOR RPM	REEL RPM	CLIPS PER FOOT						
			1 MPH	2 MPH	3 MPH	4 MPH	5 MPH	6 MPH	7 MPH
4	540	840	82.32	41.16	27.44	20.58	16.464	13.72	11.76
5	540	840	102.9	51.45	34.3	25.725	20.58	17.15	14.7
6	540	840	123.48	61.74	41.46	30.87	24.696	20.58	17.64
7	540	840	144.06	72.03	48.02	36.015	28.812	24.01	20.58
8	540	840	164.64	82.32	54.88	41.16	32.928	27.44	23.52
9	540	840	185.22	92.61	61.74	46.305	37.044	30.87	26.46

## Mowing with V-Reel Equipped Mowers

1. Lower the mowing units to the ground.
2. Engage the tractor PTO at low speed to avoid shock to the mower power train.
3. Select appropriate tractor gear range (maximum 5-1/2 mph or 8.8 km/h at rated PTO speed). Refer to Clip Ratio on page 11.
4. Accelerate to maximum PTO speed: 500-540 rpm.

**DO NOT ENGAGE THE PTO WITH MOWERS IN THE RAISED POSITION (TRANSPORT POSITION).**

**DO NOT RAISE THE MOWING UNITS WITH THE PTO ENGAGED,**

**MAKE SURE THE PTO IS DISENGAGED AND THE REELS HAVE STOPPED ROTATING BEFORE RAISING THE MOWING UNITS.**

Properly adjusted and sharpened mowing units will slice a sheet of writing paper as cleanly as a pair of scissors.

## Bed knife to Reel Adjustment

A quick check of the spring spacer (Refer to illustration below) is all that is required. To properly set spring spacer, loosen jam nut (A), then turn adjuster screw nut until the spring spacer is "snug" between washers. One should be able to rotate the spring spacer by firmly gripping it.

## Backlapping

In some conditions a quick backlapping may be required in order to maintain a sharp cutting edge.

A "Backlapper" on machine reel sharpener, Locke Turf Part No. 50019543, is available to make this job quick and easy. Refer to the instruction manual of the "Backlapper" gear box for complete details regarding the backlapping procedure.

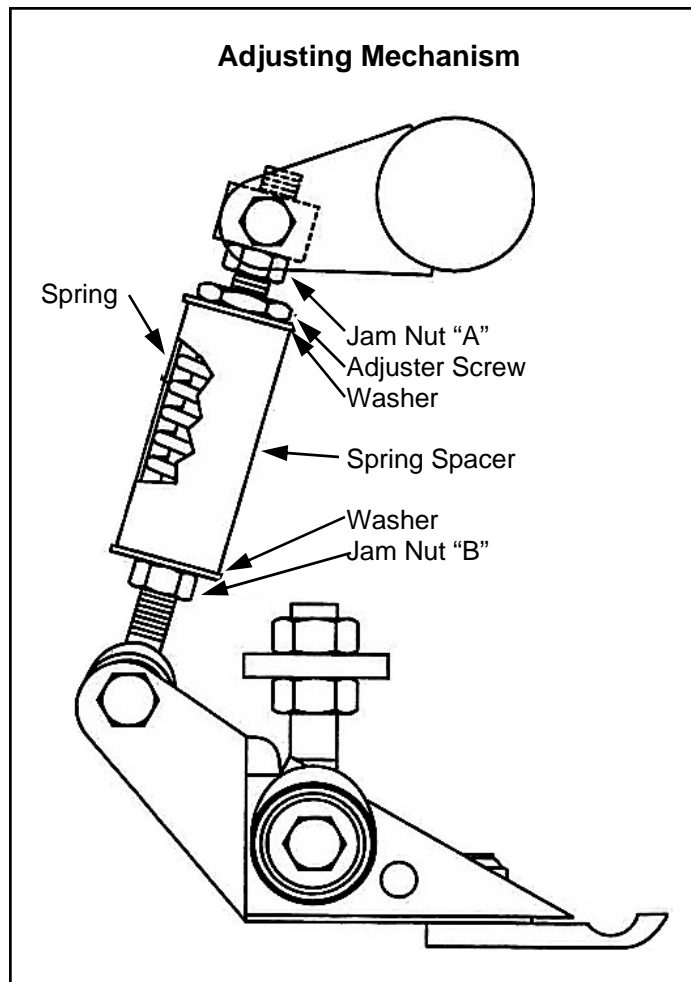

## Hydraulic Lift Operation

Refer to Hydraulic System Schematics.

### RAISING MOWING UNITS:

#### **(TRM 5000 & 7000 ONLY)**

Pressure is applied to the "lift side of the circuit. Oil passes through the check (lock) valve and restrictor to the rod end port of the hydraulic cylinder.

Maximum normal lift pressure occurs as the two rear mowing units climb the snubber ramps. When the two rear mowing units are fully engaged in the snubbers, the supply pressure will rise until the tractor's maximum or relief valve pressure is reached.

The mowing units are hydraulically locked in the "raised position by the check valve; this valve will not release until pressure is applied to the "lower" side of the circuit.

### LOWERING MOWING UNITS:

Pressure is applied to the "lower" side of the circuit. This pressure releases the check valve, allowing oil from the rod end of the hydraulic cylinder to flow back to the tractor.

#### **NOTE**

**The TRM 3000 has only two hoses with no check valve or restrictor.**

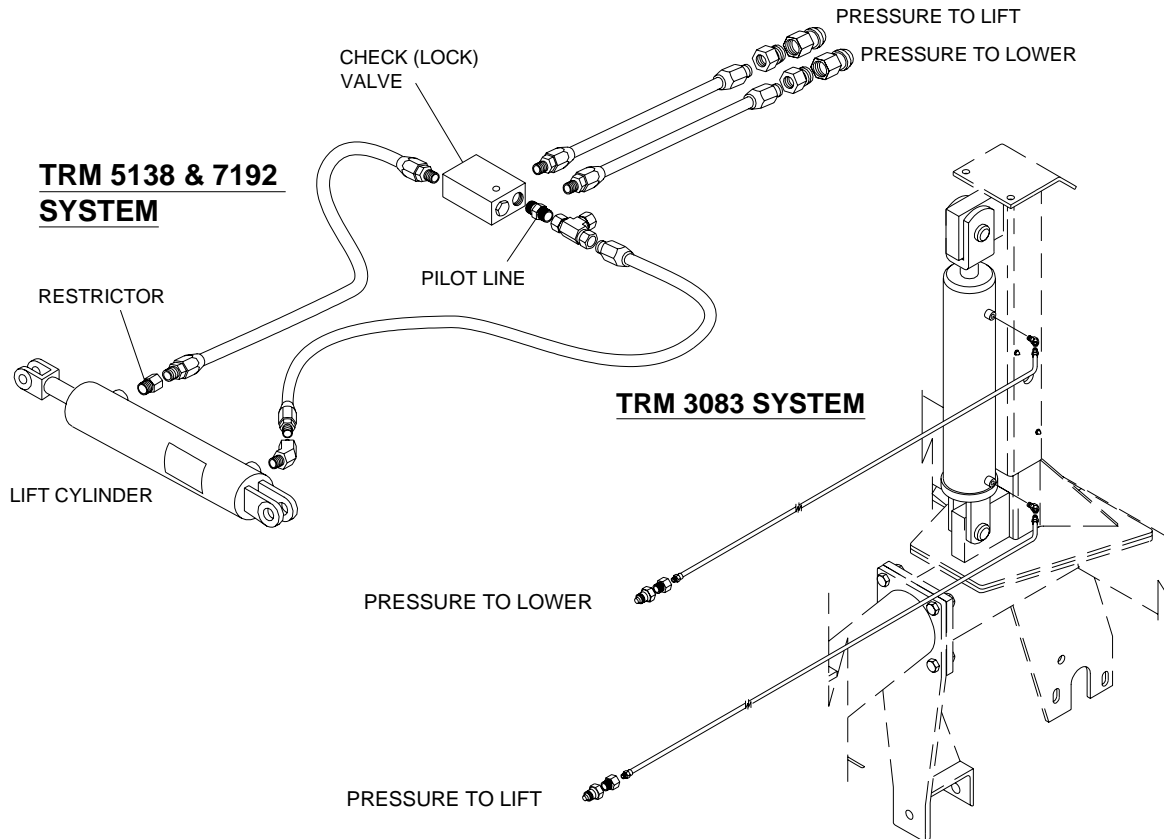

### TRM TIRE INFLATION CHART

	TIRE TYPE	INFLATION PRESSURE
TRM 3000-ROAD PACKAGE	16 X 6.5 X 8 CROSS RIB	45 psi
TRM 5000 & 7000 ROAD TIRE	18 X 8.5 X 8 CROSS RIB	35 psi
TRM 5000 & 7000 TURF TIRE	18 X 8.5 X 8 STRAIGHT RIB	24 psi

## To Lower the Mowing Unit

1. Make sure the transport safety chain is unhooked and stowed on the left rear lift arm.

### NOTE

**Do not attempt to lower the mowing units with the transport safety chain in place, as this may result in damage to the lift system.**

2. Place the tractor's external hydraulics control valve in the "lower" position. Return the valve to the center (neutral ) position when the rear mowing unit lift arms are fully down.

## To Raise the Mowing Units

1. Place the tractor's control valve in the "lift" position, Return the valve to the center (neutral) position when the rear outer mowing units have fully engaged the snubbers.

## Transport Locks

If traveling any distance or when storing the mower overnight or longer, always hook the transport safety chain between the two rear lift arms.

### NOTE:

**When transporting the mower on a truck or trailer, always block the mowing units securely to take the load off the lift chains and lift mechanism.**

## Hydraulic Hook-up

Insert the hydraulic hose quick-disconnect plugs into the female quick-disconnects on the tractor external hydraulics.

### NOTES:

1. The "lift hose runs into the port on the front of the check (lock) valve.
2. The "spare" hose guide should be mounted on the rear of the tractor. The two hoses should pass through both hose guides, so that the hoses are supported clear of the PTO shaft and drawbar at all times.
3. The quick-disconnects are SM Type 500 QC; the mower hose will fit SM Type 500 female couplers.

**If your tractor is not fitted with quick-disconnects, an adaptor kit must be used.**





## HYDRAULIC LIFT TROUBLESHOOTING

### UNITS WILL NOT LOWER

- |  |                        |
|--|------------------------|
| 1. Transport safety chain not hooked and stowed. | Unhook and stow chain. |
| 2. Quick-disconnects reversed.                   | Reverse couplings.     |
| 3. Faulty tractor hydraulic supply.              | See tractor manual.    |
| 4. Check valve pilot not operating.              | Replace check valve.   |

### UNITS WILL NOT RAISE

- |                                     |  |
|-------------------------------------|--|
| 1. Quick-disconnects reversed.      | Reverse couplings.                                     |
| 2. Insufficient hydraulic pressure. | See tractor manual.                                    |
| 3. Leaking cylinder.                | Replace cylinder seals. Replace cylinder if necessary. |

### REAR UNITS WILL NOT CLIMB ONTO SNUBBERS

- |                                     |   |
|-------------------------------------|---|
| 1. Insufficient hydraulic pressure. | See tractor manual.   |
| 2. Mechanical interference.         | Check to see that no moving parts, chains, etc. are trapped or locked. Make sure lift chains are properly adjusted. |

### UNITS WILL NOT STAY IN RAISED POSITION

- |  |  |
|--|--|
| 1. Leakage from hose between check valve and cylinder. | Tighten fitting. Replace fitting or hose if necessary. |
| 2. Leaking cylinder.                                   | Replace cylinder seals. Replace cylinder if necessary. |
| 3. Leaking check valve.                                | Replace check valve.                                   |

## Periodic Maintenance

### After every 40 hours or operation:

Grease the following points sparingly:

- Reel bearings
- Roller bearings
- Telescoping arms
- PTO drive shaft (primary drive)
- Tie rod ends (#6 and #7 mowing units)

### After every 80 hours of operation:

Grease the following points sparingly:

- Jackshaft bearings
- Hitch
- Tower jack swivel

Service the primary drive

1. Check oil level in the gearbox. If necessary, top of with good quality SAE 90 gear oil (Mobil GX90, Texaco Martak multi gear 90 or equal).
2. Grease PTO shaft universals and check the locking pins for correct operation.
3. Check belt slack and adjust if necessary.

## Tires

Tires should be checked regularly for damage, especially on units which are frequently transported on highways or rough roads.



**STANDARD TIRES ARE TERRA-TIRES AND ARE NOT RATED OR SAFE FOR EXTENDED USE OVER 10 MPH.**

Refer to tire inflation chart, page \_\_\_\_.

## Telescoping Arms

Check operation of telescoping arms by pulling up on belt. Arms should open and close freely.



## Drive Belts

Check condition of drive belts frequently. Replace damaged or overstretched belts.

## Annual Inspection

To ensure efficient operation and long life of your mower, the following checks and maintenance should be carried out before storing the equipment at the end of the mowing season:

1. Perform all services outlined in the section on periodic maintenance.
2. Check jackshaft coupling to ensure that keys are in place and bolts are fully tightened.
3. Check that all split taper bushings are secure.
4. Check transport locks and springs for correct operation. Replace broken, damaged or worn components.
5. Check that all mowing unit tie rods are secure and properly adjusted:
  - a. Set mower level on a flat surface, with center line of front and rear jackshafts the same height above ground level.
  - b. Use a string arrangement as shown in the diagram on the next page to check the alignment of the mowing units.
6. Wipe exposed cutting edges of bed knives and cylinder blades with light oil to prevent rusting.
7. Check that all safety guards are intact and securely fastened.
8. Jack up carriage frame. Remove the wheel hubs, clean and inspect the bearings and pack the cavity between the bearings with 3.2 cubic inches of good quality general purpose grease (such as Mystick JT-6 High-Temp NLGI No. 2, or equivalent). Adjust the bearings so that there is no end play but the wheel turns freely. **DO NOT OVERTIGHTEN THE BEARINGS.**
9. Check the rubber bumpers on the outer mowing unit lift stops. Replace worn or damaged bumpers.

## Main Component Locations

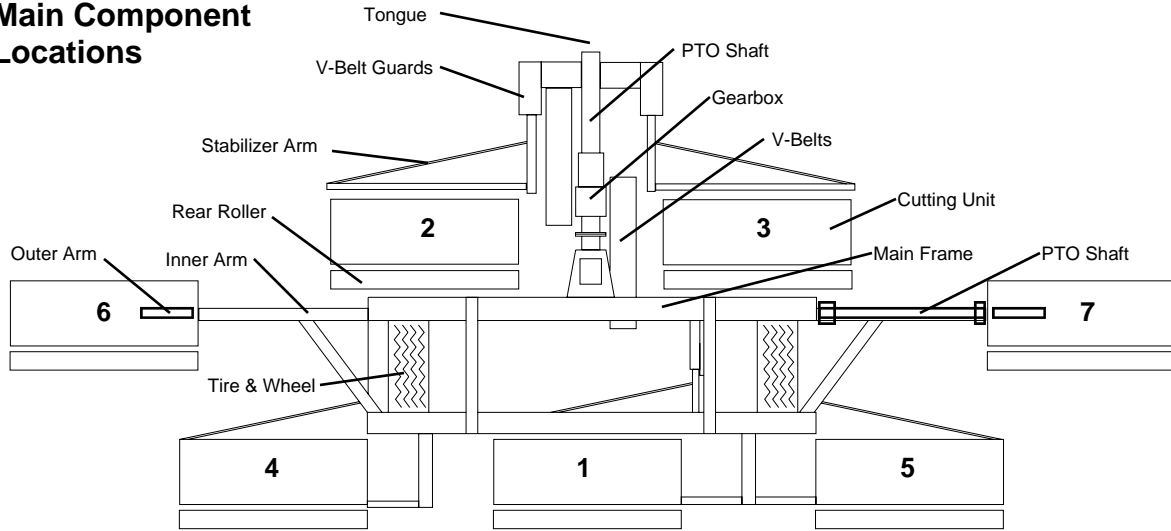

## TIE ROD ADJUSTMENT CHECK

PULL THE STRING ACROSS THE BACK OF THE MOWING UNITS AS SHOWN

ADJUST ALL TIE RODS UNTIL THE STRING JUST TOUCHES ALL FRAME CORNERS THE SAME

TIE STRING HERE

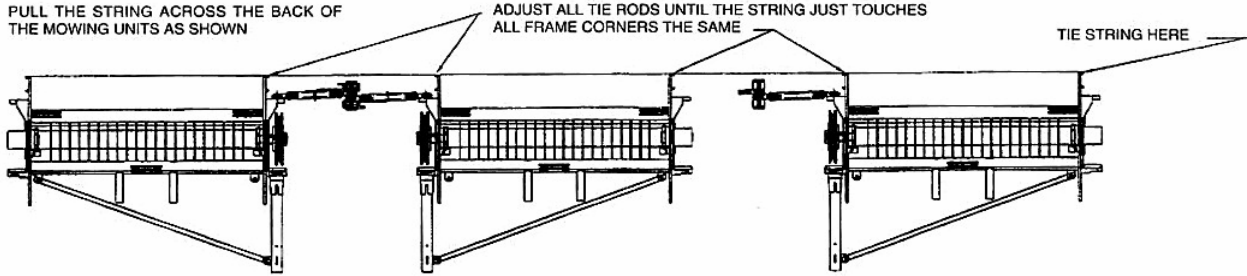

PULL THE STRING ACROSS THE BACK OF THE MOWING UNITS AS SHOWN

TIE ROD ADJUSTED TOO LONG  
TIE ROD ADJUSTED TOO SHORT

TIE STRING HERE

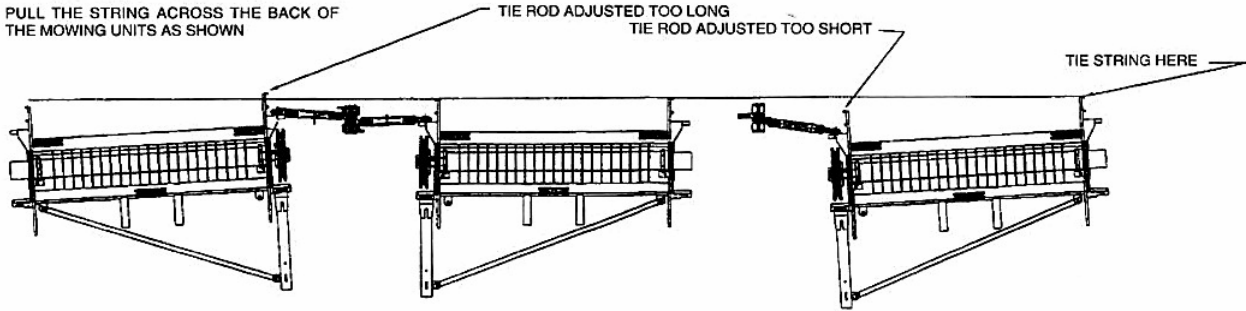

## PTO DRIVELINE LUBRICATION

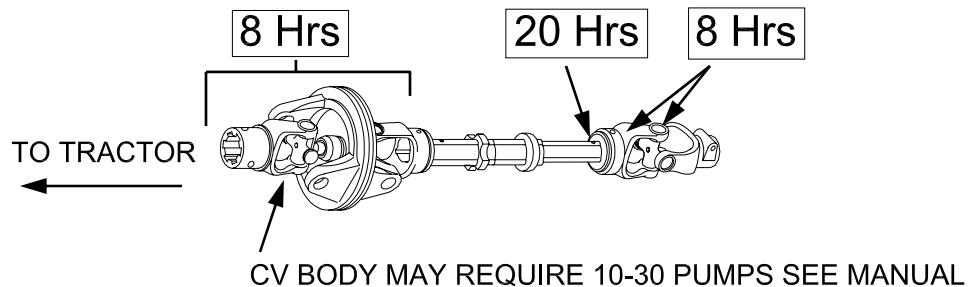

## SAFETY DECALS

To promote safe operation, Locke Turf supplies safety decals on all products manufactured. Because damage can occur to safety decals either through shipment, use or reconditioning, Locke Turf will, upon request, provide safety decals for any of our products in the field at no charge. Contact your authorized Locke Turf dealer for more information.

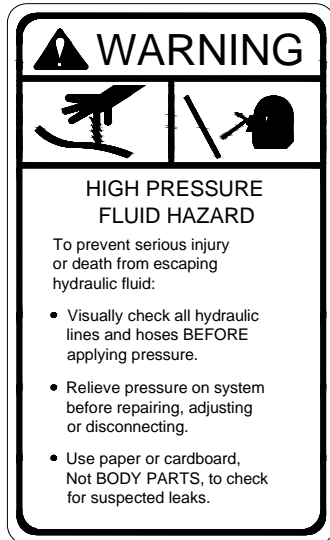

50022071



50022074



50022072

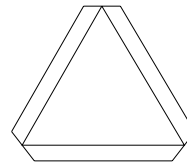

Slow Moving Vehicle Symbol



Amber Reflector 53315



Red Reflector 53316

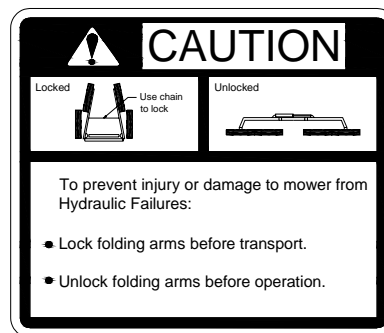

50022079



50022064

## DECALS CONTINUED



50022075



50022070

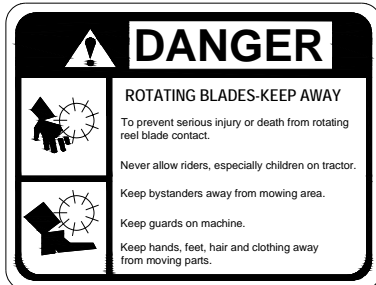

50022077

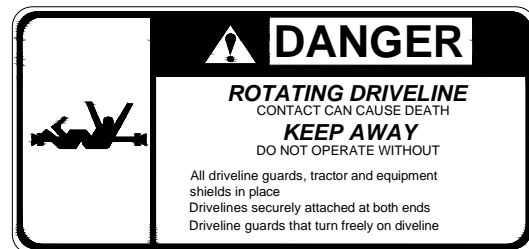

50022065

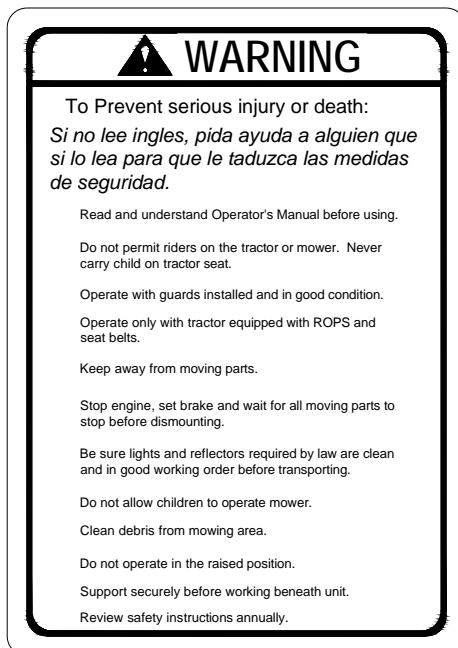

50022073



50022078



50022066

## DECALS CONTINUED



50022082



50022081

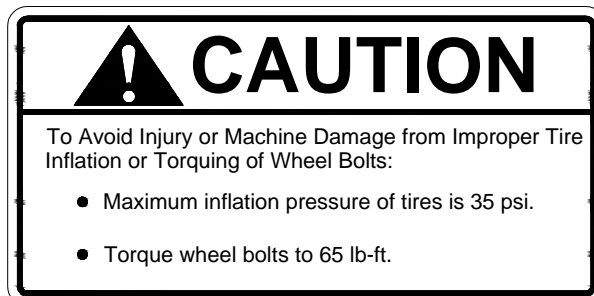

50022303

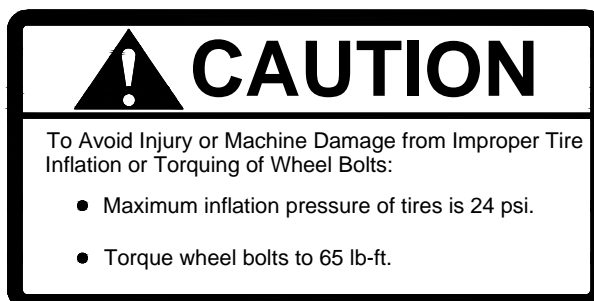

50022076

# TORQUE SPECIFICATIONS

Proper torque for American fasteners used on Locke Turf equipment.  
Recommended Torque in Foot Pounds (Newton Meters). \*

## AMERICAN Bolt Head Markings

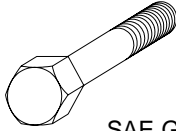

SAE Grade 2  
(No Dashes)

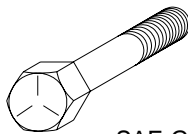

SAE Grade 5  
(3 Dashes)

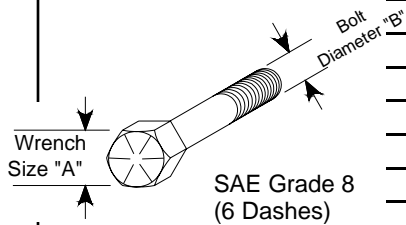

SAE Grade 8  
(6 Dashes)

WRENCH SIZE (IN.) "A"	BOLT DIAMETER (IN.) "B" AND THREAD SIZE	SAE GRADE 2	SAE GRADE 5	SAE GRADE 8
7/16	1/4 -20 UNC	6 (7)	8 (11)	12 (16)
7/16	1/4 -28 UNF	6 (8)	10 (13)	14 (18)
1/2	5/16 - 18 UNC	11 (15)	17 (23)	25 (33)
1/2	5/16 - 24 UNF	13 (17)	19 (26)	27 (37)
9/16	3/8 - 16 UNC	20 (27)	31 (42)	44 (60)
9/16	3/8 - 24 UNF	23 (31)	35 (47)	49 (66)
5/8	7/16 - 14 UNC	32 (43)	49 (66)	70 (95)
5/8	7/16 - 20 UNF	36 (49)	55 (75)	78 (106)
3/4	1/2 - 13 UNC	49 (66)	76 (103)	106 (144)
3/4	1/2 - 20 UNF	55 (75)	85 (115)	120 (163)
7/8	9/16 - 12 UNC	70 (95)	109 (148)	153 (207)
7/8	9/16 - 18 UNF	79 (107)	122 (165)	172 (233)
15/16	5/8 - 11 UNC	97 (131)	150 (203)	212 (287)
15/16	5/8 - 18 UNF	110 (149)	170 (230)	240 (325)
1-1/8	3/4 - 10 UNC	144 (195)	266 (360)	376 (509)
1-1/8	3/4 -16 UNF	192 (260)	297 (402)	420 (569)
1-5/16	7/8 - 9 UNC	166 (225)	430 (583)	606 (821)
1-5/16	7/8 - 14 UNF	184 (249)	474 (642)	668 (905)
1-1/2	1 -8 UNC	250 (339)	644 (873)	909 (1232)
1-1/2	1 - 12 UNF	274 (371)	705 (955)	995 (1348)
1-1/2	1 - 14 UNF	280 (379)	721 (977)	1019 (1381)
1-11/16	1-1/8 - 7 UNC	354 (480)	795 (1077)	1288 (1745)
1-11/16	1-1/8 - 12 UNF	397 (538)	890 (1206)	1444 (1957)
1-7/8	1-1/4 - 7 UNC	500 (678)	1120 (1518)	1817 (2462)
1-7/8	1-1/4 - 12 UNF	553 (749)	1241 (1682)	2013 (2728)
2-1/16	1-3/8 - 6 UNC	655 (887)	1470 (1992)	2382 (3228)
2-1/16	1-3/8 - 12 UNF	746 (1011)	1672 (2266)	2712 (1992)
2-1/4	1-1/2 - 6 UNC	870 (1179)	1950 (2642)	3161 (4283)
2-1/4	1-1/2 - 12 UNF	979 (1327)	2194 (2973)	3557 (4820)

Proper torque for American fasteners used on Locke Turf equipment.  
Recommended Torque in Foot Pounds (Newton Meters). \*

## METRIC

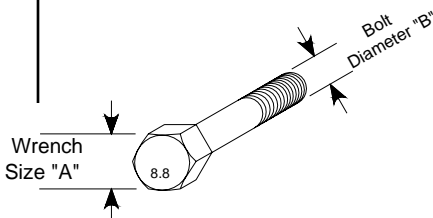

Numbers appearing on bolt heads  
Indicate ASTM class.

\*Use 75% of the specified torque value  
for plated fasteners. Use 85% of the  
specified torque values for lubricated  
fasteners.

WRENCH SIZE (mm) "A"	BOLT DIA. (mm) "B"	ASTM 4.6	ASTM 8.8	ASTM 9.8	ASTM 10.9
8	5	1.8 (2.4)		5.1 (6.9)	6.5 (8.8)
10	6	3 (4)		8.7 (12)	11.1 (15)
13	8	7.3 (10)		21.1 (29)	27 (37)
16	10	14.5 (20)		42 (57)	53 (72)
18	12	25 (34)	74 (100)	73 (99)	93 (126)
21	14	40 (54)	118 (160)	116 (157)	148 (201)
24	16	62 (84)	167 (226)	181 (245)	230 (312)
30	20	122 (165)	325 (440)		449 (608)
33	22		443 (600)		611 (828)
36	24	211 (286)	563 (763)		778 (1054)
41	27		821 (1112)		1138 (1542)
46	30	418 (566)	1119 (1516)		1547 (2096)



**Locke Turf**

307 Highway 52E, Opp, Alabama, 36467, (334) 493-1300