

OWNER'S GUIDE

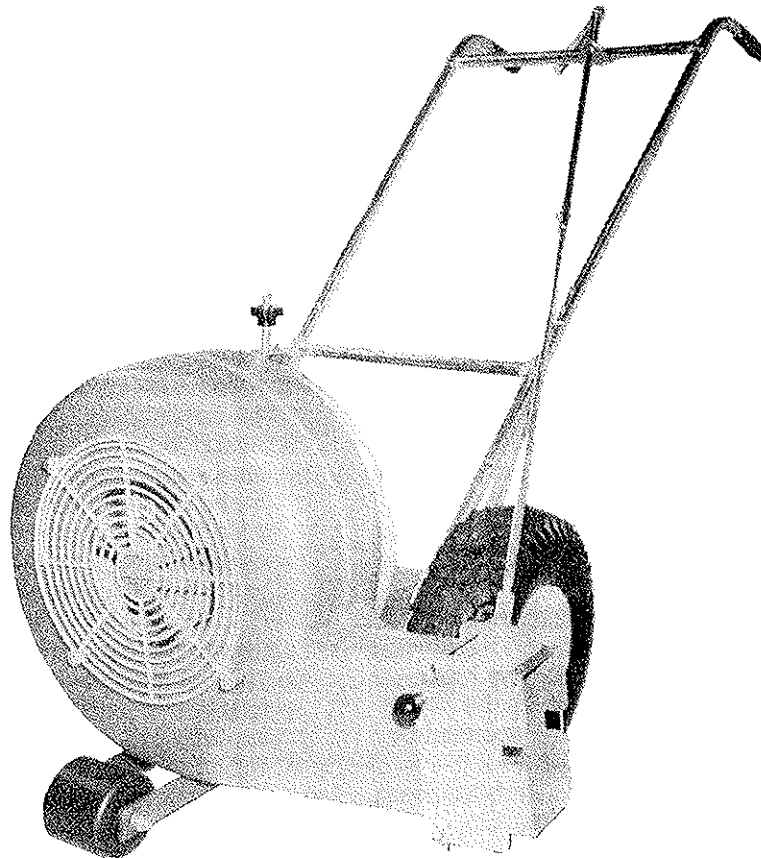

hurricane[®]
MODEL NO. HC-8600



AF-616

**READ THESE INSTRUCTIONS
BEFORE SETTING UP AND OPERATING MACHINE**

PARKER SWEEPER COMPANY

Box 1728

Springfield, Ohio 45501-1728

Plate No. 1115 (Rev. 6-9-86)

ASSEMBLY INSTRUCTIONS

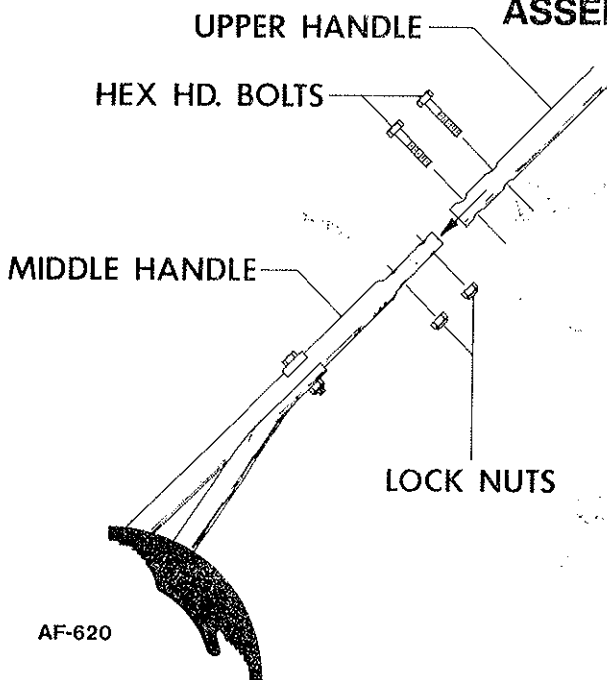

To Assemble Handles

1. Remove the hex hd. bolts and lock nuts from the lower end of the left and right hand upper handles.
- NOTE: The left hand upper handle can be determined from the right hand upper handle by; the two small holes in the upper part of handle for mounting a throttle control. (If applicable with engine being used.)
2. Insert the left hand upper handle onto the left middle handle.
 3. Insert the right hand upper handle onto the right middle handle.
 4. Align the holes in the upper handles with those in the middle handles. Replace the hex hd. bolts and lock nuts, removed in step 1, **DO NOT TIGHTEN**.
 5. Remove the hex hd. bolt and lock nut from the upper part of both left and right hand upper handles.
 6. Place upper cross bar assembly on top side of upper handles. Align holes in cross bar with those in upper handles.
 7. Replace hex hd. bolts and lock nuts, removed in Step 5, and tighten.
 8. Check alignment of handle assembly. The hex lock nuts, used to secure the upper handles to the middle handles, have been left loose to allow movement between the holes and the bolts.
 9. Move handles until proper alignment is accomplished. Once handles are aligned tighten all lock nuts.
- NOTE: Handles may have to be held while tightening lock nuts. Do Not bend tubing to accomplish proper alignment.
10. Lock nuts should be tightened enough that at least two of the bolts threads extend through the nut. It may be necessary to collapse the tubing **SLIGHTLY** to accomplish this.

To Attach An Engine To The Chassis

1. Place the engine on the chassis with the shaft extending forward away from the handles.
2. The engine should be centered between the handles with the front face of the engine (back plate mounting surface) even with the front of the chassis.

3. Secure the engine to the chassis with bolts thru holes provided. Some engines may require drilling additional holes to retain the correct engine position.
4. Before continuing with assembly remove the ignition wire from engine spark plug.

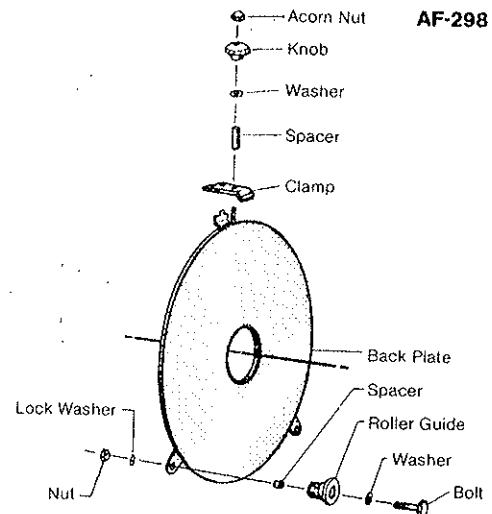

To Attach The Back Plate To An Engine

1. Lay the fan housing on a bench or floor with the grill down against the bench or floor.
2. Remove the back plate by first unscrewing the knob, at the top of the fan housing, until it stops against the lock nut at the top end of the threads.
3. Lift the clamp and rotate it 90° either direction.
4. Push the back plate sideways to disengage the two rollers.
5. Remove the back plate assembly by lifting it upward off the fan housing.
6. Attach the back plate to the engine mount using four spacers provided, with bolts thru the back plate mounting holes. The rollers on the back plate must be outward away from the engine. NOTE: The back plate **MUST** be centered around the engine shaft, with the rollers parallel to the bottom of the chassis.

To Attach The Fan To The Engine

1. The fan must be spaced out from the back plate. A spacer has been provided. It will satisfy most engine applications.
2. The spacer must stop against a shoulder on the engine shaft, not against a bearing, housing or seal.
3. The fan must be held secure from rotation on the engine shaft by a close fitting key. A keyway is provided in the fan.
4. Two heavy special washers are provided. Both washers and a lockwasher must be used between the bolt head and the fan to prevent concaving and loosening of the bolt that secures the fan.
5. The fan bolt must have a minimum of 1 and 1 half times the bolt diameter of engagement into the engine shaft.
6. Only a grade 5 or grade 8 bolt should be used to secure the fan, with a lockwasher under the bolt head.
7. The fan bolt should be torqued to the applicable specification for the bolt used. (7/16-20 bolt requires 55-59 ft. lbs.).

To Install The Blower Housing

1. Place the blower housing over the fan and position the pivot ring against the back plate.
2. Push the back plate upward until the rollers on the bottom firmly engage the pivot ring.
3. Rotate the clamp to engage the pin on the top of the back plate thru the hole in the clamp. NOTE: The toe of the clamp must engage over the top of the pivot ring.
4. Tighten the knob at the top of the back plate, to lock the pivot ring in place.

CAUTION: Before attaching the ignition wire to the spark plug, pull the recoil starter cord to rotate the fan, to make sure the fan can rotate freely.

Attach the ignition wire to the spark plug.

Control Rod Connection

1. Remove the contour hd. bolt, lockwasher and hex. nut from the upper control rod.
2. Telescope the lower and upper control rods together.
3. Replace the contour hd. bolt, lock washer and hex nut thru the control rods.

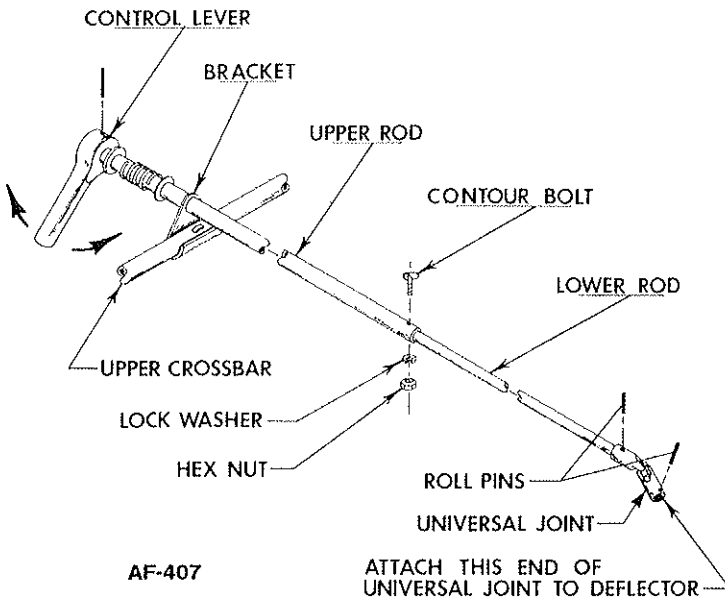

Blower Adjustment "Hi or Low"

When adjusting the blower housing to HI or LOW BLOW, engine must be stopped.

1. To adjust the blower housing to a desired position, turn the knob counter-clockwise to loosen.
2. Pivot the exhaust deflector to the desired position and tighten the knob.
3. The exhaust deflector control rod assembly will pivot with the blower housing to any position.

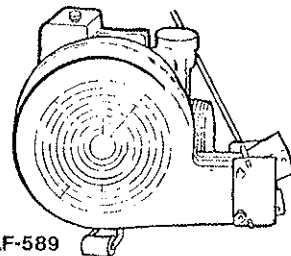
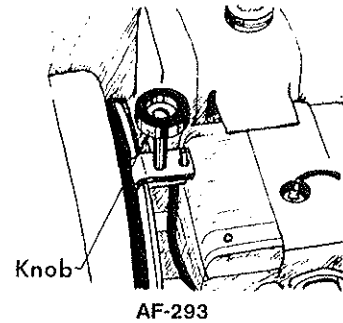

Blower housing in the Low Blow Position.

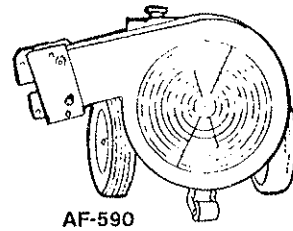

Blower housing in the Hi Blow position.

To Control Deflection Angle

By turning the lever on the control rod assembly, the deflection angle can be changed to control the air flow from the exhaust deflector.

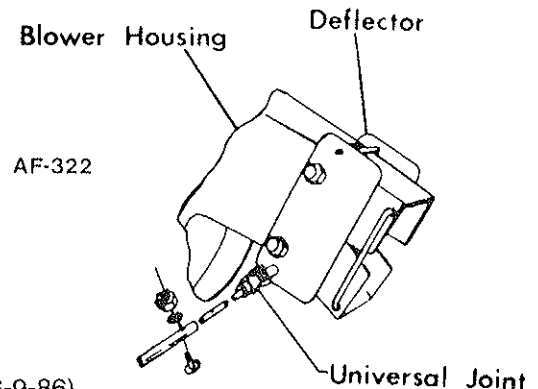

HANDLE ASSEMBLY

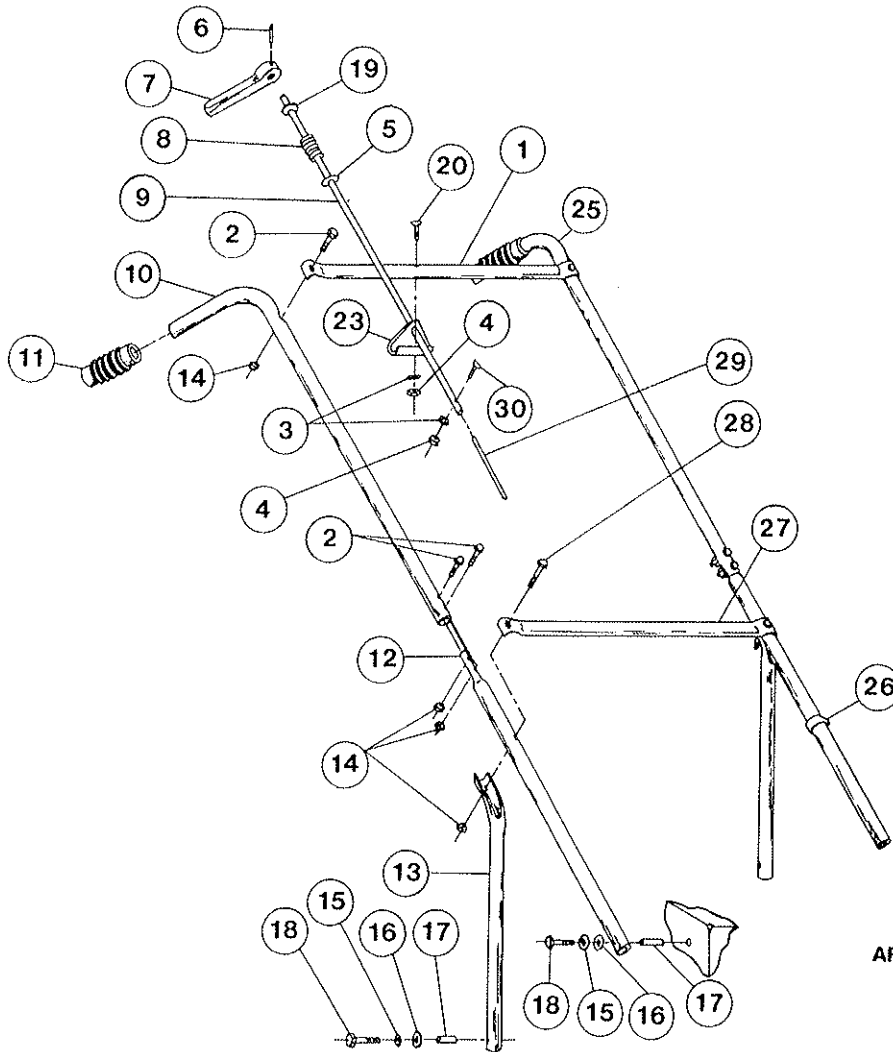

AF-594

PARTS LIST

Ref. No.	Part No.	Qty. Per Unit	Description	Ref. No.	Part No.	Qty. Per Unit	Description
1	82-249-B	1	Upper Cross Bar	16	945-516	4	Flatwasher, 5/16
2	65-416-24	6	Bolt, Hex Hd. 1/4-20 x 1 1/2	17	80-238-A	4	Insert
3	935-416	2	Lockwasher, Spring, 1/4-20	18	65-516-24	4	Bolt, Hex Hd., 5/16-18 x 1 1/2
4	335-416	2	Nut, Plain Hex 1/4-20	19	55-161-A	1	Special Washer
5	81-164-A	1	Nylon Washer	20	62-416-24	1	Bolt, Contour Hd., 1/4-20 x 1 1/2
6	67-521-A	1	Roll Pin 3/16 x 1	23	82-252-A	1	Bracket
7	76-34-A	1	Deflector Control Lever	25	83-18-C	1	Upper Handle
8	74-135-A	1	Spring	26	80-276-A	1	Clamp-Snap On
9	76-235-A	1	Control Rod, Upper	27	81-47-B	1	Cross Bar Lower
10	80-321-C	1	Upper Handle	28	65-416-28	2	Bolt, Hex Hd. 1/4-20 x 1 3/4
11	80-232-A	2	Handle Grips	29	SA-1146-A	1	Lower Control Rod Assy.
12	82-149-B	2	Middle Handle	30	69-416-16	1	Bolt, Contour Hd. 1/4-20 x 1
13	82-155-C	2	Handle Back Brace				
14	365-416	8	Nut, Hex Lock 1/4-20				
15	935-516	4	Lockwasher, Spring 5/16				

BLOWER ASSEMBLY

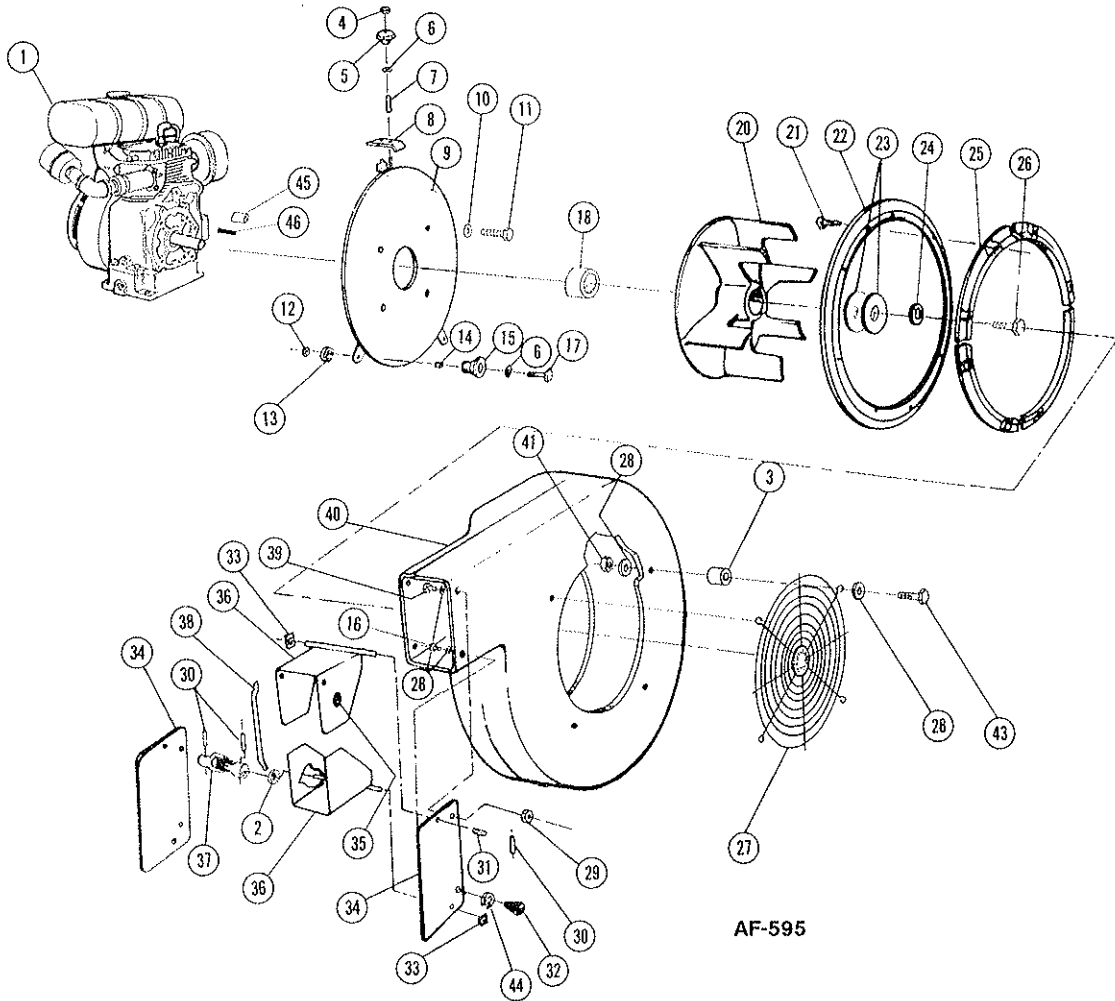

AF-595

PARTS LIST

Ref. No.	Part No.	Qty. Per Unit	Description	Ref. No.	Part No.	Qty. Per Unit	Description
1	Reference	1	Engine	23	82-138-B3	2	Special Washer
2	81-120-A	1	Spacer	24	935-716	1	Lockwasher, Spring, 7/16
3	82-142-A	4	Spacer Grille	25	73-123-C	4	Anti-Wrap
4	365-516	1	Nut, Hex Lock, 5/16-18	26*		1	Bolt, Fan
5	79-94-A	1	Knob	27	82-121-C	1	Grill
6	945-516	3	Flatwasher, Plain 5/16	28	945-416	12	Flatwasher, Plain, 1/4
7	79-67-A	1	Spacer	29	365-416	3	Nut, Hex Lock, 1/4-20
8	79-51-A	1	Clamp	30	60-62-A	3	Roll Pin, 1/8 Dia. x 3/4
9	80-316-C	1	Back Plate Weldment	31	73-372-A	1	Spring
10		4	Lockwasher, Spring	32	75-79-A	1	Knob
11		4	Bolt, Hex Hd.	33	75-80-A	2	Shaft, Retainer
12	335-516	2	Nut, Plain Hex 5/16-18	34	73-124-B	2	Exhaust, Side Plate
13	935-516	2	Lockwasher, Spring 5/16	35	73-406-A	1	Friction Disc
14	80-101-A	2	Bushing	36	73-125-B	2	Exhaust Deflt. Weld
15	80-144-A	2	Guide, Roller	37	82-251-A	1	Universal Joint
16	65-416-10	1	Bolt, Hex Hd., 1/4-20 x 5/8	38	73-126-A	1	Link, Exhaust Def.
17	65-516-20	2	Bolt, Hex Hd., 5/16-18 x 1 1/4	39	65-416-12	3	Bolt, Hex Hd. 1/4-20 x 3/4
18	73-415-A	1	Spacer, Fan	40	82-118-D	1	Blower Housing
20	73-118-D	1	Fan Wheel	41	364-416	4	Nut, Hex Lock (Thin) 1/4-20
21	505-416-24	8	Screw, Flat Hd. Mach. 1/4-20 x 1 1/4	43	65-416-24	4	Bolt, Hex Hd., 1/4-20 x 1 1/2
22	79-129-C	1	Pivot Ring	44	935-416	1	Lockwasher, Spring, 1/4
				45	79-139-A	4	Spacer-Back Plate
				46	63-130-A	1	Fan Key 1/4 x 1 3/4

CHASSIS ASSEMBLY

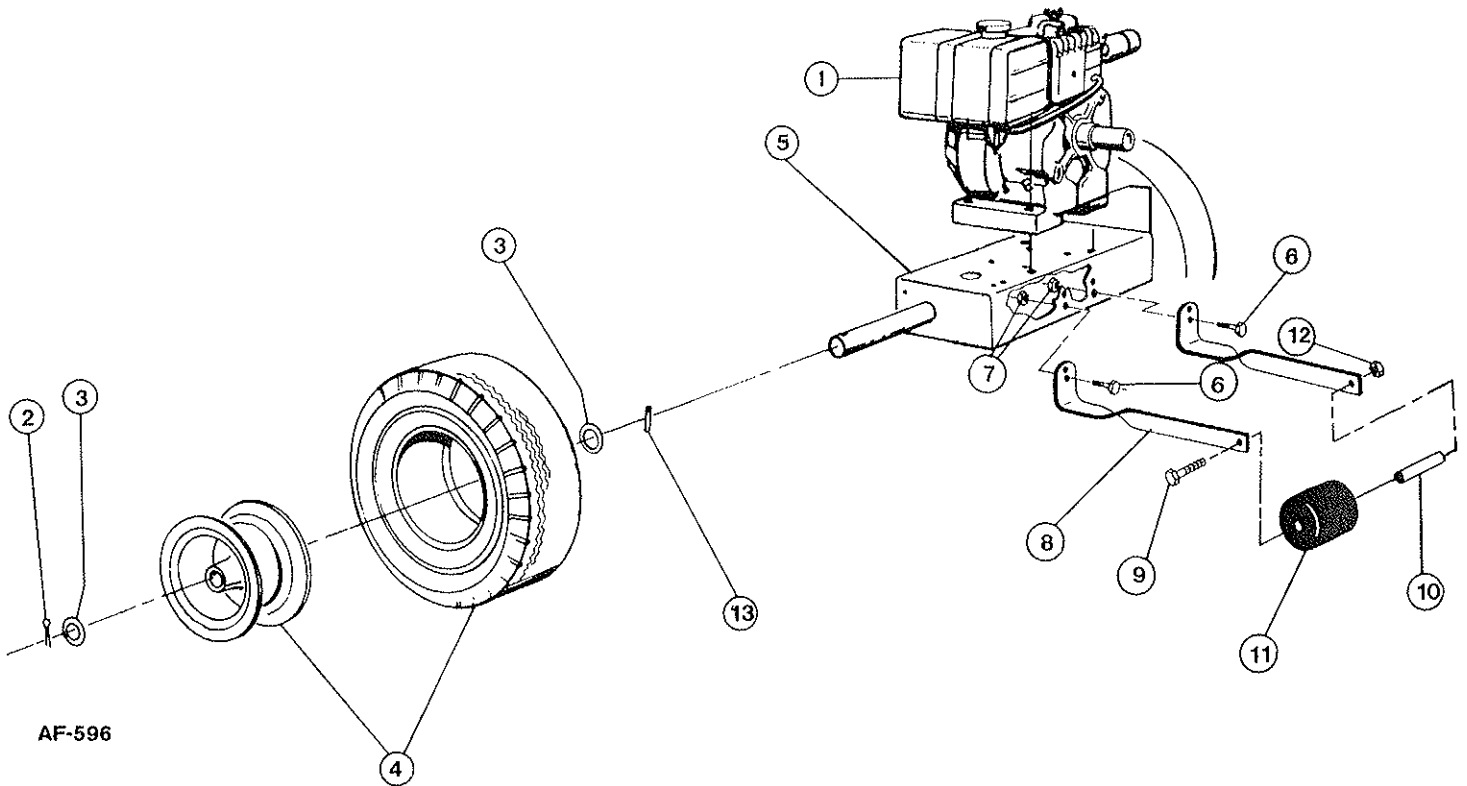

PARTS LIST

Ref. No.	Part No.	Qty. Per Unit	Description	Ref. No.	Part No.	Qty. Per Unit	Description
1	Reference	1	Engine	6	65-416-12	4	Bolt, Hex Hd. 1/4-20 x 3/4
2	380-432-20	2	Cotter Pin 1/8 x 1 1/4	7	365-416	4	Nut, Hex Lock 1/4-20
3	945-1216	4	Flatwasher, Plain 3/4	8	82-147-B	2	Roller Support
4	SA-231-B	2	Wheel Assembly	9	60-816-88	1	Bolt, Hex Hd. 1/2-20 x 5 1/2
	68-447-B	2	Wheel Hub	10	84-259-A	1	Bushing
	68-312-A	2	Tire	11	66-436-A	1	Rubber Roller
5	82-113-C	1	Chassis Weldment	12	363-816	1	Nut, Hex Lock 1/2-20
				13	67-521-A	2	Roll Pin 3/16 x 1