

OWNER'S GUIDE

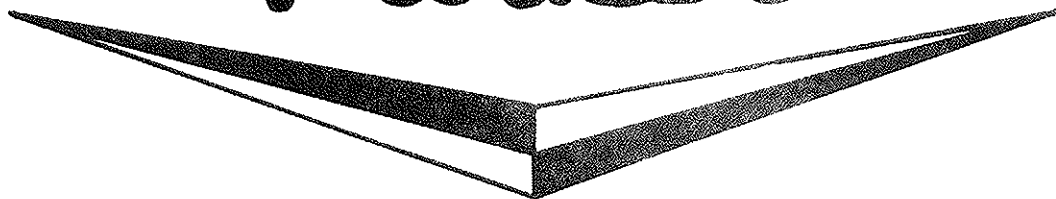

Parker®



HURRICANE®

MODEL HT-8880-K

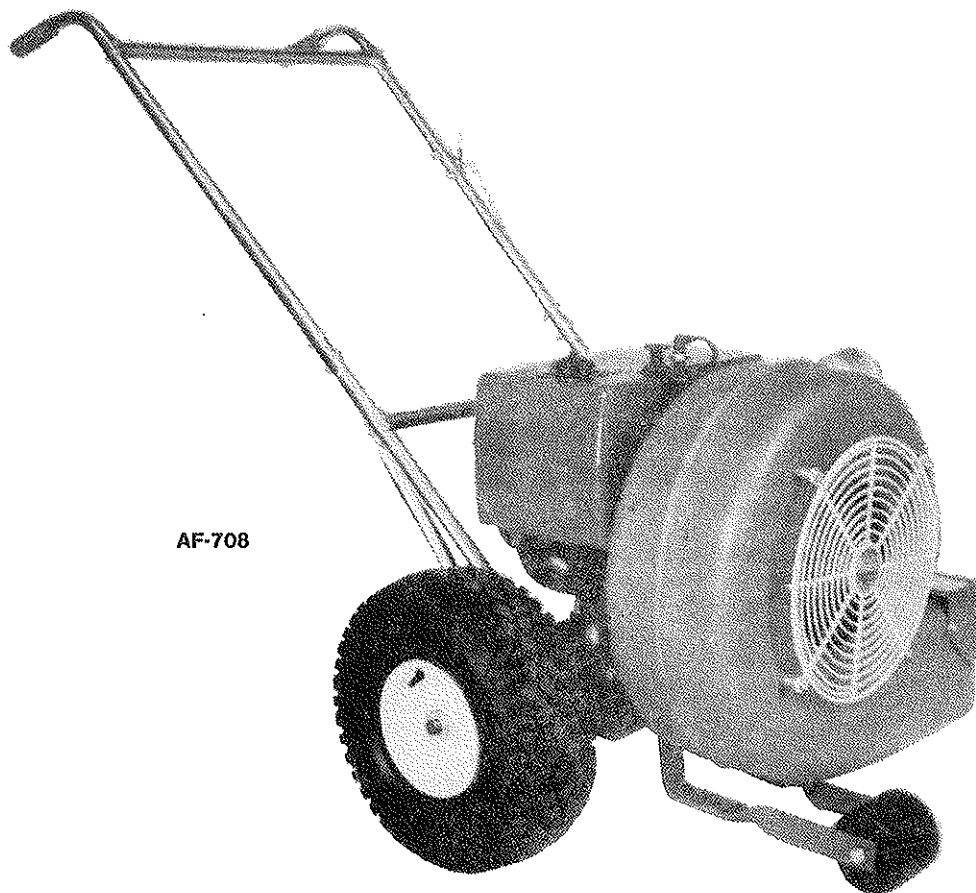

AF-708

**READ THESE INSTRUCTIONS
BEFORE SETTING UP AND OPERATING MACHINE
BE SAFE. PROTECT YOUR FAMILY, YOUR FRIENDS, YOURSELF.
OBSERVE ALL SAFETY INSTRUCTIONS.**

PARKER SWEEPER COMPANY

Box 1728

Springfield, Ohio 45501-1728

Plate No. 1391

88-87-A

TO THE OWNER

These instructions were written to assist you in the assembly and operation of your Hurricane. **READ THE INSTRUCTIONS** thoroughly **BEFORE** attempting to assemble and operate the machine so that you are familiar with the complete procedure and the safety precautions.

RULES FOR SAFE OPERATION



The following safety precautions are suggested to prevent damage to the equipment or injury to the operator or nearby persons.

1. TO PREVENT ACCIDENTAL STARTING ALWAYS REMOVE THE SPARK PLUG before working on the engine or equipment driven by the engine.
2. DO NOT RUN THE ENGINE IN AN ENCLOSED AREA. Exhaust gases contain carbon monoxide which is an odorless and deadly poison.
3. DO NOT FILL GASOLINE TANK WHILE ENGINE IS HOT OR RUNNING. Spilling gasoline on a hot engine may cause a fire or explosion.
4. DO NOT leave machine unattended while running.
5. DO NOT ALLOW machine to blow in direction of people or objects that could be injured by blown materials.
6. AVOID operating machine in dangerous places where steep slopes or loose debris will endanger the safety of operator or other people.

OPERATING INSTRUCTIONS

1. Before starting the engine, read the Operating and Maintenance instruction Manual. Add proper gasoline and oil to correct level.
2. Engine should be "broken in" by running at 1/2 throttle for 30 minutes and full throttle for an additional 30 minutes.
3. Machine will operate effectively by either pushing or pulling.
4. For moving heavy debris such as sticks, cleaning out flower beds, anything heavier than leaves, use the deflector in the down position.
5. For controlled blowing of leaves into windrows and stacking use the deflector in the up position.

IMPORTANT

ALWAYS GIVE THE FOLLOWING INFORMATION WHEN ORDERING REPAIR PARTS:

- | | |
|-------------------------------|---------------------------|
| 1. Part Number (Not Ref. No.) | 3. Description of Part |
| 2. Quantity Needed | 4. Model No. of Hurricane |

If unable to obtain parts locally, write down above information and send to:
PARKER SWEEPER CO., BOX 1728, SPRINGFIELD, OHIO 45501

Your unit is right hand (R.H.) or left hand (L.H.) as you stand behind it.

BLOWER ASSEMBLY

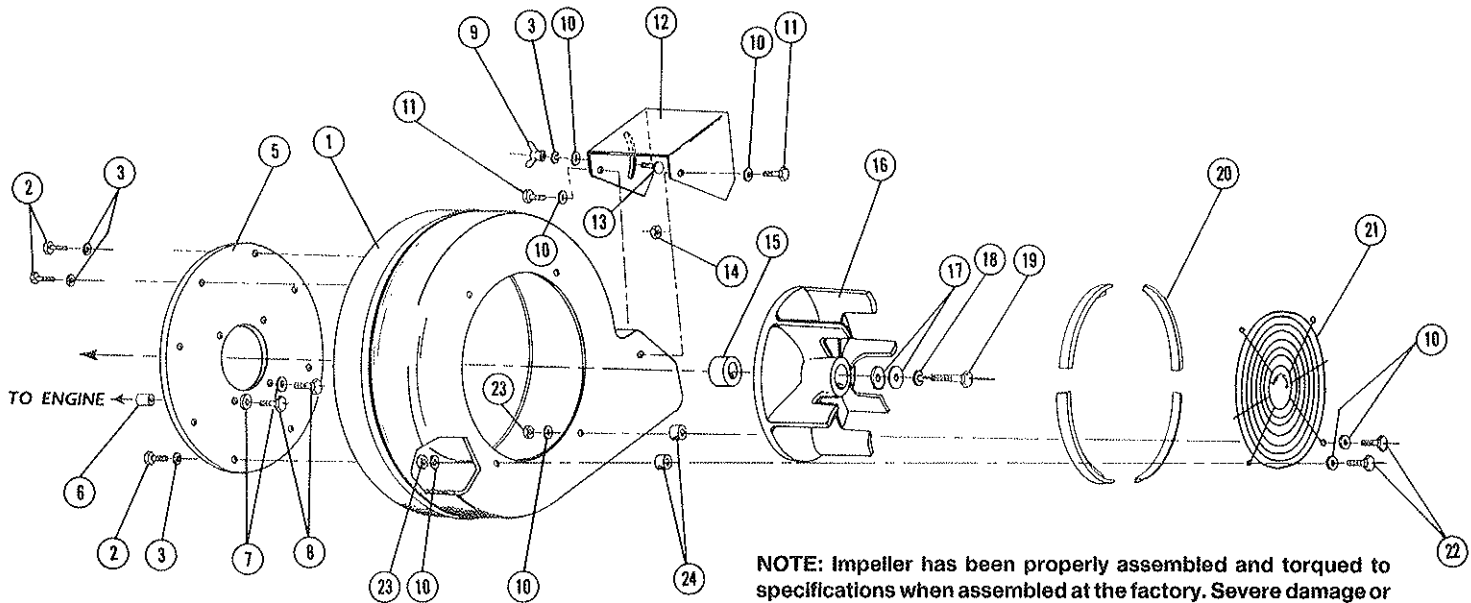

AF-379

NOTE: Impeller has been properly assembled and torqued to specifications when assembled at the factory. Severe damage or injury may result if impeller is removed and improperly assembled with different hardware or torqued incorrectly. The bolt must be of grade 5 and the specified length. Torque a 7/16 bolt at 45 to 49 ft. lbs. Parker Sweeper is not liable for any changes by owner.

PARTS LIST

Ref. No.	Part No.	Qty. Per Unit	Description
1	82-117-D	1	Blower Housing
2	65-416-16	8	Bolt, Hex. Hd. 1/4-20 x 1
3	935-416	9	Lockwasher, Spring 1/4
5	83-52-C	1	Back Plate
6	82-108-A	4	Spacer
7	935-616	4	Lockwasher, Spring 3/8
8*	65-616-24	4	Bolt, Hex Hd., 3/8-16 x 2 1/2
9	351-416-18	1	Wing Nut 1/4
10	945-416	11	Flatwasher, Plain 1/4
11	65-416-12	2	Bolt, Hex Hd. 1/4-20 x 3/4
12	82-130-C	1	Exhaust Deflector
13	70-416-12	1	Carriage Bolt, 1/4-20 x 3/4
14	365-416	2	Nut, Hex Lock 1/4-20
15	73-117-A	1	Fan Spacer
16	73-118-D	1	Fan Wheel
17	82-138-B3	2	Special Washer
18	935-716	1	Lockwasher, Spring 7/16
19	60-716-24	1	Bolt Hex Hd. 7/16-20 x 1 1/2
20	73-123-C	4	Anti-Wrap Segment
21	82-121-C	1	Grille
22	65-416-24	4	Bolt Hex Hd. 1/4-20 x 1 1/2
23	364-416	4	Nut, Hex Lock 1/4-20
24	82-142-A	4	Spacer

*Torque at 10.5-12.5 Ft. Lbs.

ENGINE ASSEMBLY

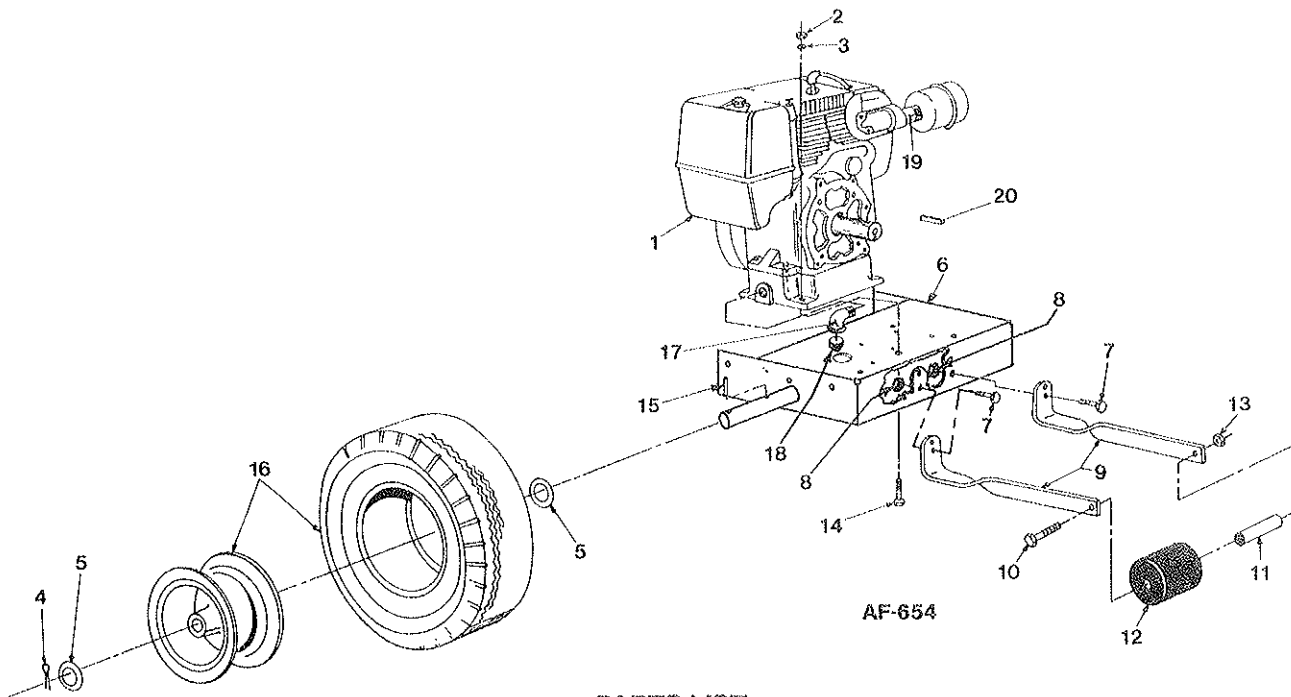

PARTS LIST

Ref. No.	Part No.	Qty. Per Unit	Description
1	**	1	Engine
2	365-616	4	Nut, Hex Lock 3/8
3	945-616	4	Flatwasher, Plain 3/8
4	380-432-20	2	Cotter Pin 1/8 x 1 1/4
5	945-1216	4	Flatwasher, Plain 3/4
6	88-91-C	1	Chassis Weldment
7	65-416-12	4	Bolt, Hex Hd. 1/4-20 x 3/4
8	365-416	4	Nut, Hex Lock 1/4-20
9	82-147-B	2	Roller Support
10	60-816-88	1	Bolt, Hex Hd. 1/2-20 x 5 1/2
11	84-259-A	1	Bushing
12	66-436-A	1	Rubber Roller
13	363-816	1	Nut, Hex Lock 1/2-20
14	65-616-20	4	Bolt Hex Hd. 3/8-16 x 1 1/4
15	67-521-A	2	Roll Pin
16*	SA-231-B	2	Wheel Assembly
	68-447-B	2	• Wheel Hub
	68-312-A	2	• Tire
17	57-81-A	1	Street Elbow, 1/2 x 90°, Galvanized
18	---	1	Plug (Supplied with Engine)
19	---	1	Black Pipe Nipple 1 x 4 (Supplied with Engine)
20	63-130-A	1	Key

*Inflate to a Max. of 30 lbs.

**Kohler Model: M8T Spec. PA-301551.

ASSEMBLY INSTRUCTIONS

OBSERVE SAFETY RULES AT ALL TIMES. DON'T TAKE CHANCES!

UNPACKING

1. Remove all loose items from the carton.
2. Do not discard the carton or inserts until the unit is completely assembled.
3. Whenever the terms left or right hand, or "L" and "R", are used, it means from a position standing behind the unit facing forward. All hardware is on the unit in its proper location.

HANDLE ASSEMBLY

NOTE: See AF-380 Handle Assembly to the back of this owner's guide for reference to numbers used in the following instructions.

1. Remove Hex Hd. Bolts (7) and Hex Lock Nuts (9) from the bottoms of the Upper Handles (1) and (10).
2. Place Upper Handles (1) and (10) over the ends of the Middle Handles (4).
3. Align the lower holes in both Upper and Middle Handles. Replace Hex Hd. Bolts (7), removed in step 1, to each of the lower holes.
4. Lift Handles until the Back Braces (5) can be assembled to Bolts (7) assembled in step 3. Assemble Hex Lock Nuts (9). **DO NOT TIGHTEN.**
5. Align the upper holes in both Upper and Middle Handles. Assemble the remaining two Hex Hd. Bolts (7) and Hex Lock Nuts (9). **DO NOT TIGHTEN.**

NOTE: Check Alignment of Handle. The Hex Lock Nuts have been left loose to allow movement between the holes and the Bolts. Do not bend tubing to accomplish proper alignment.

6. Once Handles are aligned tighten all Hex Lock Nuts (9). NOTE: Nuts should be tightened enough that at least two of the Bolt threads extend through the Nut. It may be necessary to collapse the tubing SLIGHTLY to accomplish this.

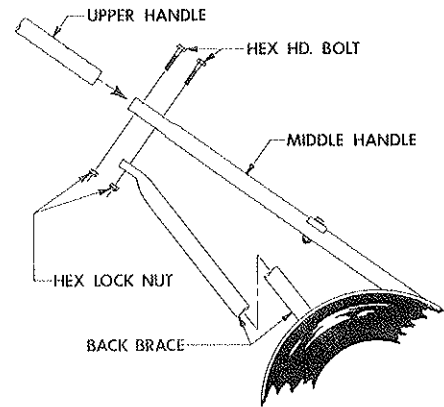

THROTTLE HOOKUP

1. Remove Throttle Control (16) from the right Middle Handle (4).
2. Straighten the Throttle Cable out and run it up the Left Hand Handles (10) and (4).
3. Attach the Throttle Control (16) to the Upper Left Hand Handle (10) with the two Oval Head Screws (15) and Hex Nuts (18) furnished.
4. Attach Snap-On Clamp (8) to Handle to secure Throttle Cable.
5. Make sure no bends are less than 8" radius.

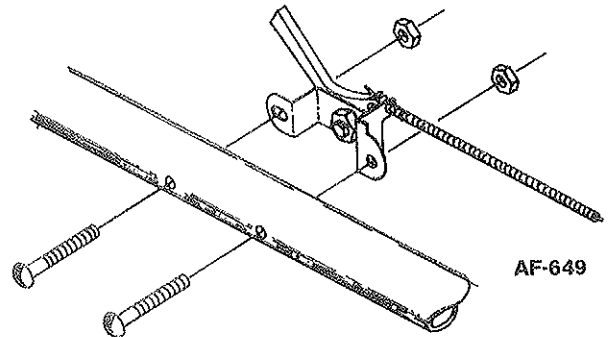

OPERATION AND MAINTENANCE INSTRUCTIONS

WARNING: The engine contains no oil when shipped. Read the Engine Instruction Manual and add the proper type and amount of oil and gas before starting engine.

1. Read engine manual carefully. Be sure to know how to start and stop engine before operating unit.
2. The unit is designed to operate at full throttle, and will work effectively by either pushing or pulling.
3. To clean an area, start at the outer perimeter and blow the material toward the center.
4. When cleaning large areas or if debris is very dense, it may be best to split the area into smaller plots and blow the material into several small piles rather than one large one. As the area being cleaned becomes smaller, reduce the engine speed to prevent blowing the collected debris into the area already cleaned.
5. The Air Deflector can be adjusted up or down per your requirements, by loosening the Wing Nut. When blowing heavy debris, such as wet leaves or twigs use Deflector in down position. Place Deflector in up position for blowing dry leaves and other light debris.

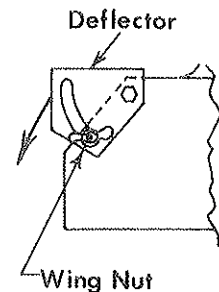

NOTE: Parker Sweeper Co. is continually striving to improve its products. We must, therefore, reserve the right to make improvements or changes, when it becomes practical and possible to do so, without incurring any obligation to make changes or additions to the equipment previously sold.

**SAFETY IS IMPORTANT! DO NOT IGNORE IT!
OBSERVE IT! BE SAFE**

HANDLE ASSEMBLY

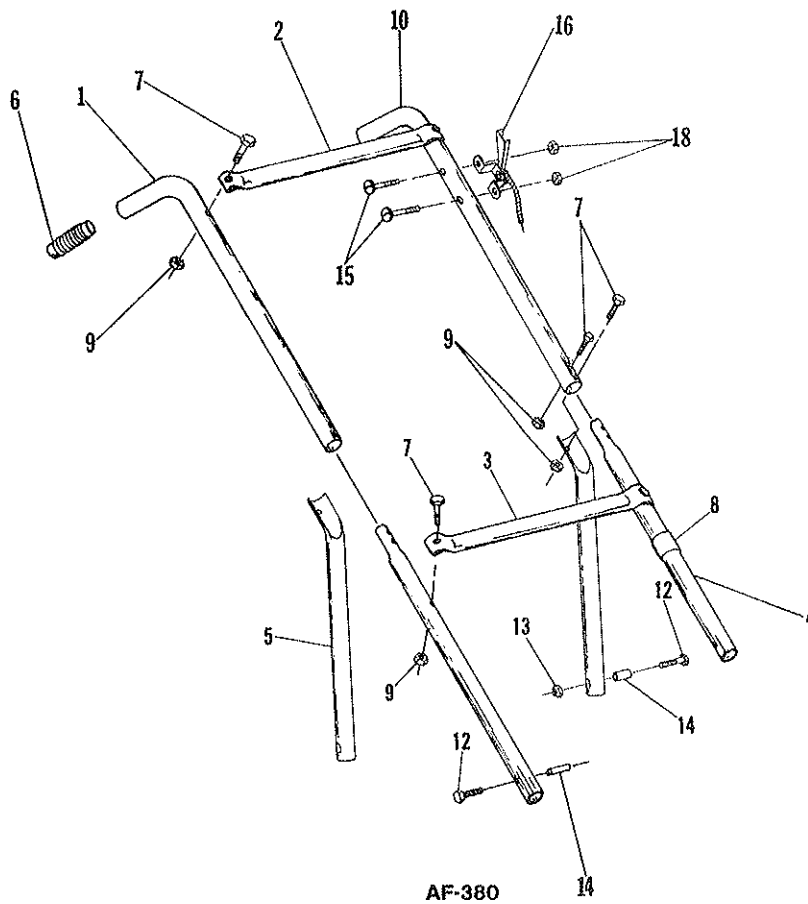

PARTS LIST

Ref. No.	Part No.	Qty. Per Unit	Description
1	80-321-C	1	Upper Handle R.H.
2	81-04-B	1	Crossbar, Upper
3	81-47-B	1	Crossbar, Lower
4	82-149-B	2	Middle Handle
5	88-94-C	2	Handle Back Brace
6	80-232-A	2	Handle Grip
7	65-416-24	8	Bolt, Hex Hd. 1/4-20 x 1 1/2
8	80-276-A	1	Clamp, Snap on Mounting
9	365-416	8	Nut, Hex Lock 1/4-20
10	83-18-C	1	Upper Handle L.H.
12	65-516-24	4	Bolt, Hex Hd. 5/16-18 x 1 1/2
13	364-516	2	Nut, Hex Lock (Thin) 5/16-18
14	80-238-A	4	Insert
15	515-10-20	2	Screw, Rd. Hd. Mach 10-24 x 1 1/4
16	83-25-B-36	1	Throttle Control
18	365-10	2	Nut, Hex Lock 10-24