

OWNERS GUIDE



Parker™



VACUUM SWEEPER VAC-35 GASOLINE AND LP ENGINE

MODEL NO. PV-8108-AK-SP, 8108-AK-SP-LP



**READ THESE INSTRUCTIONS
BEFORE SETTING UP AND OPERATING MACHINE**

**NOTE: FOR OPERATION ON TURF OR OTHER PAVED SURFACES,
TURF WHEEL KIT MA-255 D, MUST BE INSTALLED IN PLACE OF CASTER.**

PARKER SWEEPER COMPANY Box 1728 Springfield, Ohio 45501

GENERAL INFORMATION

1. The Vac's covered by this owners guide are shipped complete in one box. Follow all instructions on assembly very carefully. Whenever a difference in instructions occurs either a separate instruction or an "Explanation Note" will be given.

2. Unpack Nose Cone, Spin-Pak, Upper Handle Assembly, Bag Platform and Filter Bag. All hardware is on the unit in its proper location. If something is missing, notify the factory or your local distributor to obtain parts needed. **DO NOT** discard any of the cartons or inner packing until machine is completely assembled.

3. Tip box over so blower housing is on top of engine. Pull unit out of box and stand it up. Move box out of the way. Whenever the terms Left and Right or L. and R. are used herein, it should be understood to mean from a position standing behind the unit facing in a forward direction.

4. **SPIN-PAK** Assemble the Spin-Pak to the Blower Housing by removing the four bolts and slipping the ring over the Housing neck. Line up the holes and insert four $\frac{1}{4}$ -20 x $\frac{5}{8}$ bolts. Assemble washers and nuts to bolts. "**DO NOT TIGHTEN.**"

"**CENTER UP**" Spin-Pak and tighten top bolt. Press ring around the Housing on the sides and tighten the side bolts, finally tighten the bottom bolt.

5. The Intake Housing should be attached to the front of the Blower Housing by inserting the hinge boss behind the hinge rod on the Front Cover, item 27, next swing the Intake Housing, item 38, until the slot fits over the adjusting screw and can be locked in place by tightening knob, item 23.

6. Adjust the height of the intake housing in relation to the floor by loosening the jam nut on the caster and threading the caster in or out of the bracket. When the desired height is determined, lock the caster in place by tightening the jam nut against the bracket. Normal floor clearance for intake housing is $\frac{3}{4}$ to $1\frac{1}{4}$ ".

NOTE: If your sweeper is going to be used primarily for turf sweeping, the optional "wheel turf kit" should be installed on the unit in place of the caster.

YOUR SAFETY IS OUR CONCERN. READ ALL SAFETY RULES AND OPERATING INSTRUCTIONS BEFORE ATTEMPTING TO START OR OPERATE THIS EQUIPMENT. FAILURE TO FOLLOW SAFETY RULES AND OPERATING INSTRUCTIONS MAY RESULT IN SERIOUS INJURY.

IMPORTANT

ALWAYS GIVE THE FOLLOWING INFORMATION WHEN ORDERING REPAIR PARTS:

- | | |
|-------------------------------|------------------------|
| 1. Part Number (Not Ref. No.) | 3. Description of Part |
| 2. Quantity Needed | 4. Model No. of VAC-35 |

If unable to obtain parts locally, write down above information and send to:
PARKER SWEEPER CO., BOX 1728, SPRINGFIELD, OHIO 45501

Your unit is right hand (R.H.) or left hand (L.H.) as you stand behind it.

7. To attach bag platform loosen one bolt in bag platform crossbrace and remove the other one. This allows the bag platform to be squeezed at open end. Insert bag platform on the hinge pins between the handle brackets. Reinsert the bolt in the crossbrace and tighten both bolts. Bag platform should stay securely in place while sweeping. To remove reverse the procedure for attaching.

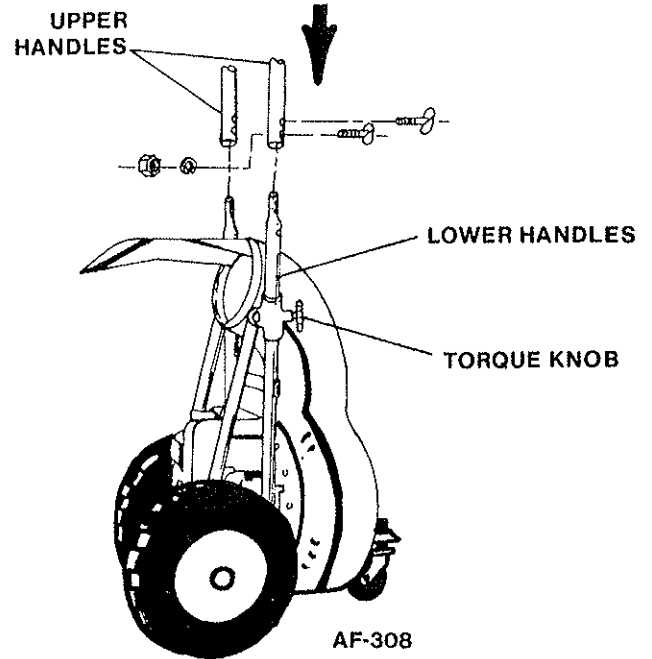
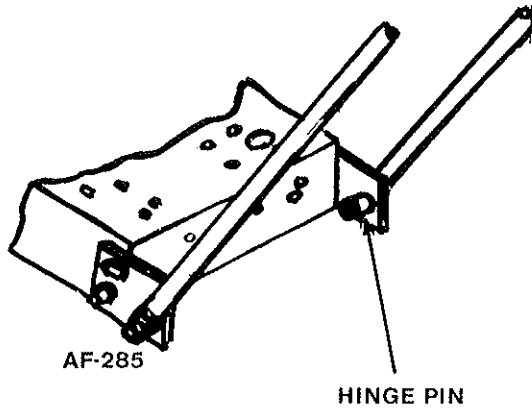

8. Remove contour bolts, hex nuts and lockwashers from the end of the upper handle. Insert upper handle assembly onto the lower handle, making sure holes at the end of upper handles are aligned with holes at top of lower handles. Reinsert contour bolts, add lockwashers and hex nuts.

9. Loosen torque knob on lower handle so handles are free to move. From behind the unit pull down on handles with both hands until top edge of pivot bracket reaches end of upper handle. Screw torque knob in until tight, so knob makes contact with lockwashers. Handles should be locked into position; if not, repeat above procedure.

10. Tighten all bolts and nuts. Bring nuts up to a "snug" position all the way around, check handle assembly for alignment and, if OK, then give each a final tightening. If alignment is needed, be sure nuts are just loose enough in all the joints to permit movement between the holes and the bolts. This should be enough to result in correct alignment. Do not bend tubing to accomplish proper position.

Be sure that the bolts are pulled down tight enough for one or more bolt threads to extend through the nut. It may be necessary to collapse the tube SLIGHTLY to accomplish this.

IMPORTANT

WARNING: The engine contains NO OIL. Read the Engine Instruction Manual carefully before operating the Vac-35. Be sure you know how to start and stop the engine before proceeding further. Do not start the engine until all assembly is finished.

Check Oil Before Starting!

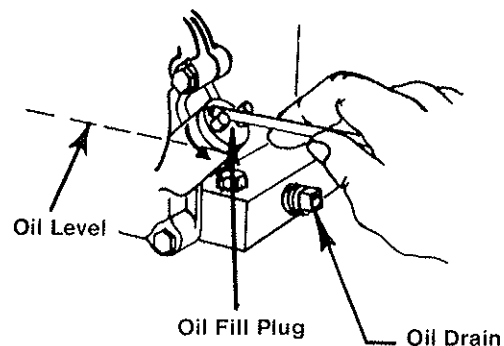

AF-313

BE SAFE. PROTECT YOUR FAMILY. YOUR FRIENDS. YOURSELF. OBSERVE ALL SAFETY INSTRUCTIONS.

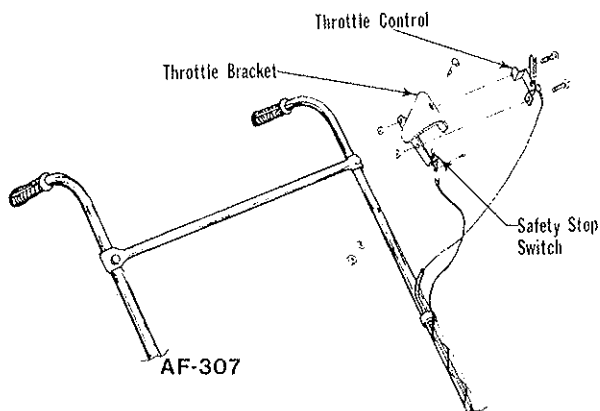

A. To install throttle control assembly and attach safety stop switch wire (where applicable), remove the throttle control assembly from the lower right hand handle. Straighten the throttle cable and run it up the left hand handle and attach to throttle bracket. Avoid placing sharp bends in the throttle cable.

B. Attach throttle cable to upper handle with snap on cable clamp which was removed on right bottom side. See handle assembly drawing for approximate location of clamps.

C. Hook throttle control to the bracket plate using the two oval head screws and two nuts furnished.

D. See drawing above for reference on assembly of stop switch on 8 H.P. Kohler Unit. Wrap the electric wire from the safety stop switch around the throttle control cable four or five times. DO NOT clamp electric wire under cable clamps. Make sure lower end of wire is attached to condenser section of engine; if not, see instructions on next page. Attach upper end of wire to stop switch on bracket by turning small screw part way out. Push wire terminal under small screw and tighten.

E. NOTE: See L.P. assembly drawing for reference on F through J.

F. If your Vac-35 has been purchased with Liquid Propane Fuel, then you must have a Vapor Withdrawal Fuel Tank. Your unit is designed to take either a 14 pound or 20 pound Fuel Tank, these are not furnished as standard equipment. They can be ordered separately from Parker Sweeper (item 22 will be included). If obtained from your local L.P. fuel supplier, he will need to install this street Ell which always remains with the tank.

G. To install, place the fuel tank in the cradle shown as Item 23. The hold-down strap (Item 24) will fit either size tank. When installing, the small hole in the tank collar must fit over the vertical pin to meet government regulations for L.P. fuel tanks. This orients the emergency relief valve so that any fuel discharged due to excess tank pressure will be directed UPWARD.

H. After tank is secured, remove the male half (Item 21) from the quick disconnect coupling and hose assembly; thread it onto tank street Ell (Item 22).

I. Attach the hose assembly to the tank by threading the quick disconnect coupling (Item 20 to Item 21).

J. See Operating Instructions for procedure to be used in starting engine with L.P. fuel.

NOTE: The following instructions are prepared to enable the operator or mechanic to make the initial assembly or to replace the engine throttle and correct any malfunction of the throttle control assembly that may occur.

DANGER:

Make a thorough inspection to see that all fastenings are tight and all parts are properly installed. DO NOT start engine without Intake and Dust Bag in place. See page 6 for installing Dust Bag and page 2 for installing intake.

If engine is started without intake attached, serious injury may result by drawing clothing or parts of the body into the fan. If engine is run without dust bag, small stones or other objects may be picked up and propelled at operator or bystanders through the unprotected opening causing serious injury.

**SAFETY IS IMPORTANT!
DO NOT IGNORE IT!
OBSERVE IT!
BE SAFE!**

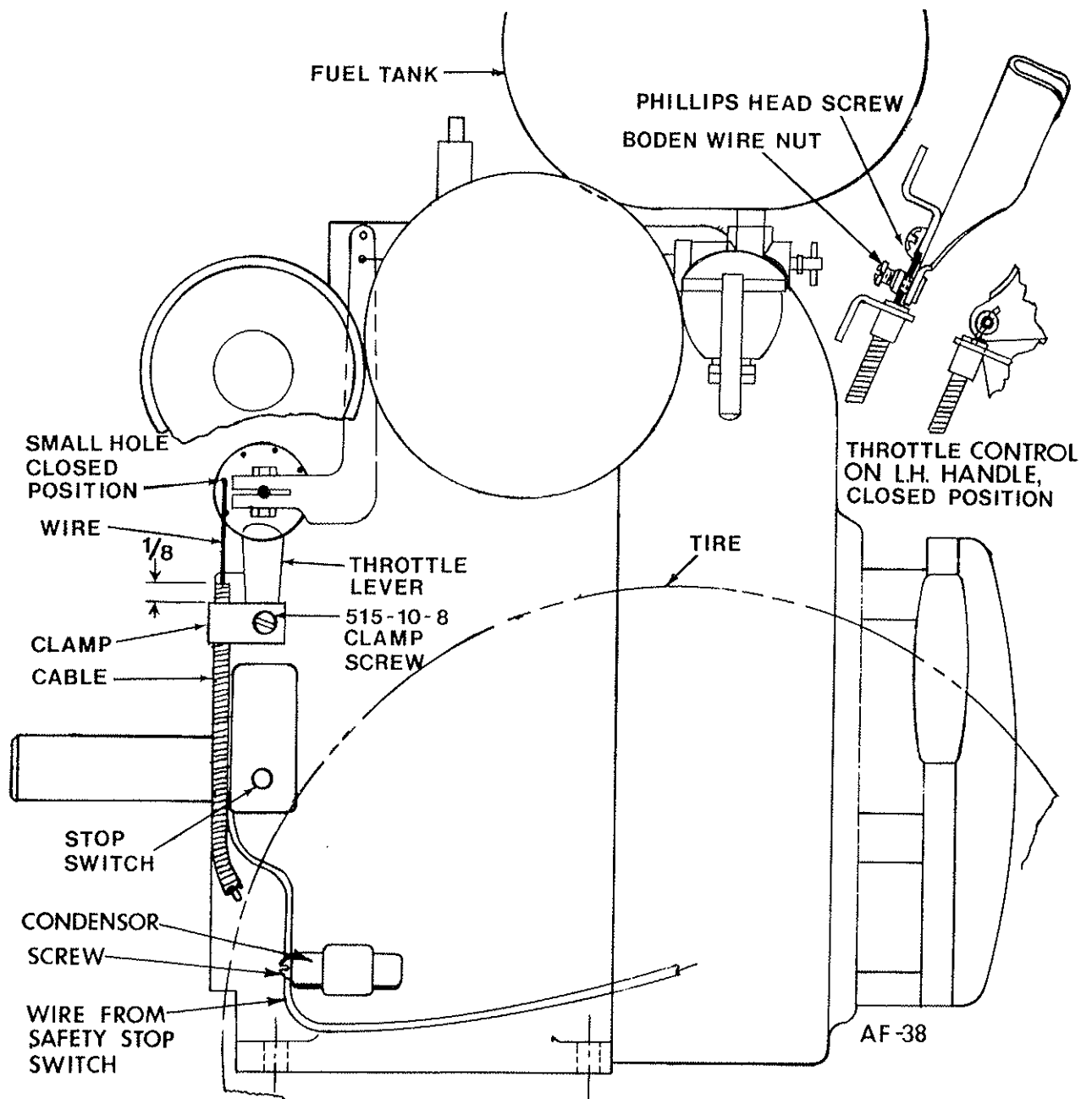

Kohler Engine Throttle Hook-up

- A. Loosen clamp screw and slip cable through clamp on left side of the screw.
- B. Insert end of wire into small hole in throttle control lever in closed position. The cable is attached to the throttle control lever bracket. At the lower end of throttle assembly, insert end of wire into small hole in throttle lever on engine as shown.
- C. With about $\frac{1}{8}$ inch of cable extending beyond clamp, tighten screw.

- D. Check travel of throttle lever and adjust as follows. With the throttle lever on engine in the closed position, the lever on handle should be as shown. Next, tighten boden wire nut on throttle lever to prevent slipping on throttle wire. Throttle assembly is now ready to test.

NOTE: If throttle does not stay open due to vibration of machine, tighten friction screw on lever assembly until there is sufficient friction to hold throttle open.

1. This unit is equipped with a five speed transmission (five forward and one reverse speed). Note: Unit should always be started with transmission in neutral gear. Failure to do so can result in serious injury to operator and damage to unit.

2. Chain Tensioner Adjustment

A. The chain tensioner should be adjusted properly at factory before shipment. Chain should be checked periodically for chain tension and wear on chain tensioner. If chain tensioner should need replaced or chain tension adjusted, follow instructions below.

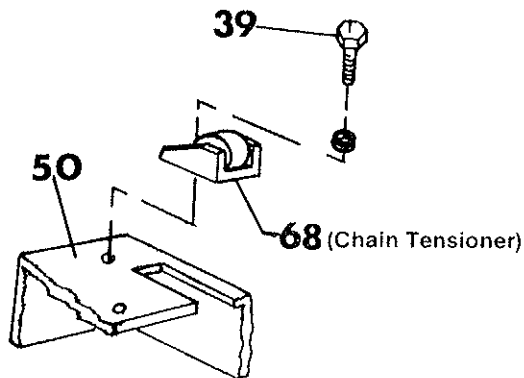

3. Remove the chain cover (15) by removing three 1/4-20 hex head bolts (14). Loosen 5/16-18 hex head bolt (39) until chain tensioner (68) will slide back and forth on the chassis (50). Slide the tensioner forward (toward the chain) until the tensioner will not slide further. Pull tensioner back about 1/8" and retighten 5/16-18 hex head bolt (39). Check chain tightness by pushing down and lifting chain between the tensioner (68) and the differential sprocket (41). Chain should move approximately 1/8" when checked as described above, if adjusted properly. If chain is adjusted too loosely it will jump sprocket teeth. If adjusted too tightly the chain may break or cause excessive wear on bearings.

4. Loosen 1/4-20 nut (48) holding bracket (12) to handle assembly until bracket will slide back and forth for proper adjustment.

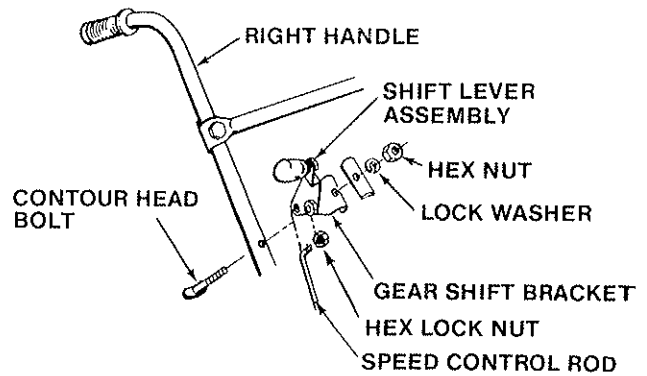

5. Speed control rod (19) should be inserted into the hole in shifter lever (13). Secure with hex nuts, (one on both sides of shifter lever). Before connecting control rod (19) at control arm (20), transmission must be in neutral gear (second from lowest lever position on transmission). Move shifter linkage (29) on transmission up or down to the neutral gear. Unit will be able to move back and forth freely if transmission is in neutral.

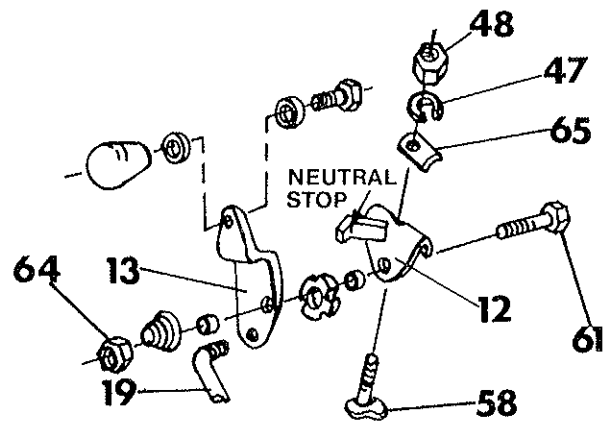

6. Slide bracket back and forth until other end of control rod (19) will align with hole in control arm on transmission. Be sure shifter lever (13) is resting against the neutral stop position while connecting control rod. Secure control rod with hairpin supplied.

7. Retighten hex nut (48) on bracket before going through any of the gears. With bracket tight, go through the forward gears and back to the neutral stop position on bracket. Unit should move back and forth freely if transmission is in neutral. If unit does not move freely, repeat above instructions, being careful to rest the shift lever (13) against the neutral stop before retightening nut #48.

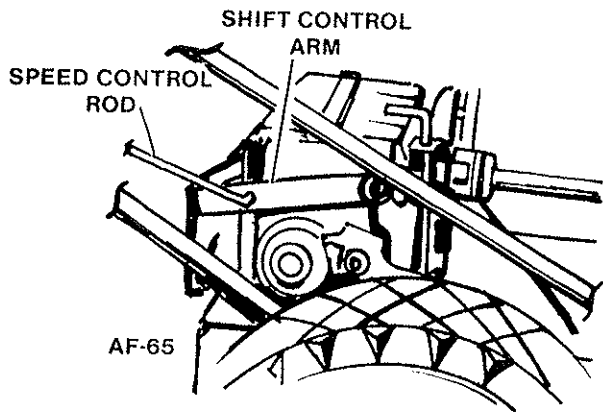

4. Belt Adjustment

A. Remove guard (37). Loosen bolts (32) which secure the bracket (55).

B. Bracket (55) has slots which permit the sheave to be moved. By moving bracket, belt tension can be adjusted.

C. Slide the bracket (55) to the right side of the chassis. Tighten the bolts and check belt for tightness.

5. Belt Replacement

A. Belt can be replaced by removing the blower housing and fan.

B. Remove the spark plug to insure that engine cannot be started.

C. Remove the following items:

1. Dust bag (1) and spin pak (1)
2. Intake housing (38)
3. Front cover (27)
4. Hex head bolt (16)
5. Lock washer (17)
6. Flat washer (18)
7. Fan retainer (19)
8. Fan (14)
9. Bolts (6 & 11)
10. Washers (7 & 12)
11. Fan Housing (9)
12. Spacers (13)
13. Guard (37)
14. Guard (53)

D. Loosen bolts which secure bracket (55) to the chassis. Remove and discard old belt. Install new belt and adjust bracket (55) so that belt tension is correct. Correct belt tension is achieved when, with moderate force applied by a finger, the top of the belt can be pressed downward about $\frac{1}{8}$ ".

6. Install Dust Bag

A. Attach the dust bag to the sweeper by placing the loops over the handles and attaching the hooks to the front bag straps, then hooking them over the lower crossbrace. Slip the neck of the dust bag over the Spin-Pak until the tie strap can be pulled tight around the housing neck just over the bead on the Spin-Pak. The bead must be covered.

Operating Instructions

1. Transmission **MUST** be in **NEUTRAL**. Pull back on gear shift until stop is reached.

A. Move **SAFETY STOP** switch to **ON** position.

B. Transmission has one reverse and five progressive forward speeds.

1. After engine has started, release the **BRAKE** by twisting lever and letting it slide down.

2. Push gear shift lever forward to first speed; continue to push gear shift lever forward until desired speed is reached.

NOTE: Transmission has five forward progressive speeds. Unit will always move from first through each of the five speeds. Unit cannot be moved from neutral to higher speed without going through the lower speeds.

3. To move from forward speed to reverse, pull back on gear shift lever until neutral stop is reached. pull lever out to the right, past the neutral stop, and straight back to reverse. Push forward for neutral position.

NOTE: FAILURE TO OBSERVE SAFETY INSTRUCTIONS MAY RESULT IN SERIOUS INJURY.

C. To STOP UNIT, PLACE GEAR SHIFT LEVER IN NEUTRAL, and move SAFETY STOP switch to OFF position. Pull up and twist brake lever ¼ turn to lock in brake position.

2. Before starting the engine read and understand the following:

A. Engine crankcase is to be filled with the proper type and amount of oil.

B. Spin-Pak is in place.

C. Dust Bag or Discharge Hose is in place.

D. Transmission is in neutral and parking brake is in the ON position.

NOTE: Do not operate the machine without first releasing the parking brake. To fail to do so places an undue strain on the transmission and may cause premature failure.

E. Intake Housing or Hose Kit is attached to the Fan Housing.

F. Heavy concentrations of sand and gravel should be avoided. These material are extremely abrasive, and while the Vac-35 will handle moderate amounts of these materials, it was not designed for heavy applications. Because these materials are extremely heavy, they will tend to collect in a lump in the bag, causing it to drag on the ground and wear out prematurely. The Vac-35 is capable of picking up empty tin cans and blocks of wood, but it was not intended for this type of service. As these pieces pass through the impeller undue stress builds up, which may damage the Vac-35. Treat your Vac-35 with reasonable care and it will repay you with long, trouble-free service.

G. The Vac-35 will handle most common kinds of debris found around industrial plants, commercial buildings, homes, and farms. Acid contaminated materials, magnesium, dust and other DANGEROUS DEBRIS should not be handled with the Vac-35 unless approved by a regulating authority expert in the handling of such hazardous materials.

H. Keep the filter bag clean. The efficiency of this unit depends on the breathing capabilities of the dust bag. On extremely dusty jobs, empty the bag often. Never allow debris to remain in the bag after use due to danger of spontaneous combustion.

3. LUBRICATION

A. Lubricate the wheel bearings and wheel axle on the caster once a week if used daily. A few drops of oil applied to the throttle control cable and wire will keep it operating smoothly.

NOTE: Refer to engine operating instructions for proper lubrication of the engine.

4. SERVICING

A. The Vac-35 is equipped with a front adjustable caster which provides any height adjustment of intake housing that is practical. Nuts must be kept tight.

NOTE: It is advisable to use the optional wheel turf kit or rubber roller kit when sweeper is used primarily for turf sweeping.

B. For servicing and operating instructions for engine, refer to Engine Manufacturers Service Manual. Careful attention to care of air cleaner and crankcase lubrication instructions will insure longer engine life. KEEP ENGINE CLEAN.

CAUTION: DO NOT WORK ON VAC-35 with engine running or idling. Bring to DEAD STOP. Remove spark plug on engine models. When changing attachments, bring engine to a complete stop.

C. For easy rolling, keep the tires inflated to 25 psi.

D. For a "like new" appearance, wash the plastic blower housing and nozzle with soap and water, rinse with clear water and wipe dry. Do not use harsh abrasives or cleansers as they will dull the finish.

E. When using hose attachment, keep it away from engine exhaust system and other parts of the engine and electric motor that may be hot enough to burn plastic hose.

5. ENGINE POWERED

A. IMPORTANT: Read the engine manual CARE FULLY before operating the Vac-35.

B. KOHLER ENGINES. The stop switch is located on the handle and on the lower left side of the engine below the exhaust.

OBSERVE SAFETY RULES AT ALL TIMES. DON'T TAKE CHANCES!

C. **SERVICING AND OPERATING INSTRUCTIONS.** Refer to Engine Manufacturers Service Manual. Careful attention to care of air cleaner and crankcase lubrication instructions will insure longer engine life. **KEEP ENGINE CLEAN.**

CAUTION: When refueling engine care should be taken not to spill fuel on hot engine. This could cause the fuel to ignite, resulting in serious injury to operator or damage to unit.

D. **SPARK ARRESTOR MUFFLER.** The drain plugs have been provided for the draining of condensation which may accumulate in the muffler. Check regularly.

E. **OXY-CATALYST MUFFLER.** When using the Oxy-Catalyst Muffler, **USE UNLEADED FUEL ONLY.** Leaded fuel will shorten the life of the catalyst, a chemical that reacts continuously with the exhaust gases to render them harmless. To be effective and start the reaction, the exhaust gas temperatures must be brought up to 500°F. The catalyst will become red hot.

(1) To determine the effectiveness of the catalyst it is necessary to measure the carbon monoxide (CO) concentrations in the exhaust gases. This can be done with a Gas Hazard Indicator. One source of this equipment is Bacharach Industrial Instrument Co., 625 Alpha Drive, Pittsburgh, Pa. 15238.

(2) If the catalyst deteriorates to the point where contaminants are not at satisfactory levels, it should be replaced.

6. LIQUID PROPANE FUEL. Available only on Kohler Engine. When a Vac-35 is equipped for liquid propane fuel, a slightly different starting technique is required. Follow steps F through L to start LP engine.

CAUTION: When installing fuel tanks, new or refills, be sure they comply with the following specifications:

A. ICC-4BA240. W.P. 240 PSI.

B. Mounted Horizontally—vapor withdrawal.

C. 14# Propane 8" dia. collar.

D. 20# Propane 10" dia. collar.

E. These specifications are also printed on the fuel tank support.

IMPORTANT: Check your local, state, and federal regulations when using liquid propane fuel to be sure you comply with all requirements for the conditions covering its use.

F. Open fuel line valve at tank.

G. Set throttle in closed position.

H. Pull starter rewind cable 3 or 4 times. This will open automatic shut-off valve allowing gas to enter engine. Engine may start at this time. If not, open throttle $\frac{1}{4}$ to $\frac{1}{2}$ and pull starter rewind cable 3 or 4 times to start engine.

I. If engine fails to start, carburetor may need adjusting. Turn in main fuel jet until it is closed. Back out 1- $\frac{1}{4}$ turns. This should be the position to allow the engine to start. After engine has been warmed up, adjust main jet for final running position by turning slowly in either direction until the engine performance is satisfactory.

J. If no success, check tank and carburetor for fuel. Check ignition and spark plug. Repeat above operations if necessary.

K. When stopping engine, shut off fuel at tank and run dry. This removes load from valves and regulators and lengthens their life. Also, this reduces danger from gas leakage while engine is not used. This procedure is mandatory under National Fire Protection Assoc. Document 58, "Storage and Handling Liquid Petroleum Gases, 1979".

L. Extra filled tanks should be stored on steel rack with tank horizontal and arrow and relief valve up.

CHAIN ADJUSTMENT, DIFFERENTIAL

To adjust chain set chassis upon 2" x 4" or equivalent. At the ends of the axle remove cotter pin, clevis pin and pull wheels off the axle. The axle bearings are not accessible for adjustment. With 5/16 wrench loosen the nuts holding the bearings on both sides of the machine.

To tighten chain, push the axle forward. Make sure that the bearings are moved forward the same amount on both sides. The same amount of the slot should be visible on the bearings on both sides. Tighten the nuts with a wrench. Slide the wheels onto the axles and reinsert the clevis and cotter pin. If chain needs to be loosened repeat same procedure only pulling axle back just slightly.

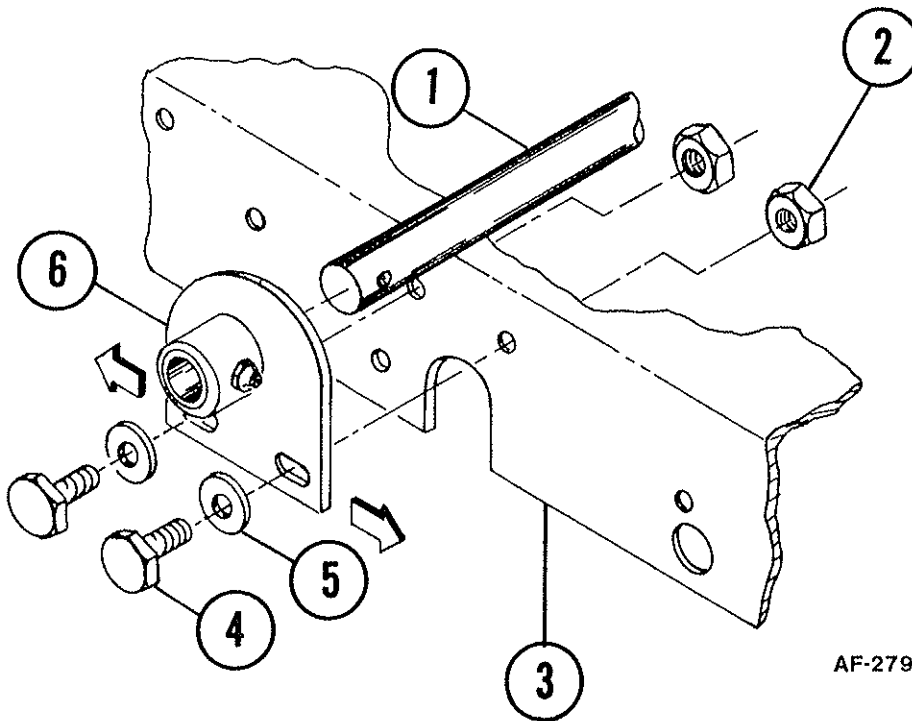

AF-279

PARTS LIST

Ref. No.	Quan.	Part No.	Description
1	1	SA-459-B	Differential Assy.
2	4	365-616	Nut, 3/8-16 Hex. Lock
3	1	81-19-D	Chassis
4	4	65-616-16	Bolt Hex. Hd., 3/8-18 x 1
5	4	945-616	Washer, Flat 3/8
6	2	SA-817-B	Bearing Assembly

OPTIONAL ACCESSORIES

NOTE: Accessory No. and Price List can be obtained from your local distributor.

1. **BAG PLATFORM:** Easily installed platform supports Bag when filled with heavy load.
2. **36" INTAKE HOUSING:** Ideal for sweeping lighter weight debris and in larger, open areas.
3. **30" INTAKE HOUSING:** Most popular size intake housing for sweeping most debris from hard surface or turf.
4. **24" INTAKE HOUSING:** For sweeping in narrow aisles or in areas where heavier objects are to be collected.
5. **DISCHARGE HOSE KIT:** Attaches to exhaust port for leading debris into truck, container, etc.
6. **HOSE ATTACHMENT 6" DIA.:** 14 Ft. length overall, fits all Vac-35 models. Attaches to impeller housing for cleaning debris from hard-to-reach areas.
7. **HOSE ATTACHMENT 4" DIA.:** 23 Ft. length overall, fits all Vac-35 models. Attaches to impeller housing for cleaning debris from hard-to-reach areas.
8. **RUBBER ROLLER KIT:** Extra-wide roller recommended primarily for turf sweeping. Height adjustable.
9. **SCRAPER BRUSH KIT:** Installs inside rear of intake housing. Loosens debris which adheres to surface. (Available for 30" intake housing only.)
10. **MAGNETIC ROD KIT:** Assembles to front of intake housing. Attracts metal objects. (Available for 30" intake housings only.)
11. **OXY-CATALYST MUFFLER:** Exhaust purifier greatly reduces carbon monoxide fumes in exhaust gases.
12. **SPARK ARRESTOR KIT:** Prevents exhausting of sparks from muffler. Safer and easily attaches to engine.
13. **LO-TONE MUFFLER:** Lowers exhaust tone level.
14. **FLEECE-LINED FILTER COLLECTOR BAG:** 11 Cu. Ft. launderable bag minimizes dust. 54" heavy duty zipper opening.
15. **LUMITE® BAG:** 10 Cu. Ft. capacity, polypropylene material. Won't fade, shrink, mildew or rot. Use when gathering damp or wet material.
16. **TURF WHEEL KIT:** Wheel Kit with kwick individual wheel adjustment. Makes for easy operation over uneven surfaces.

HOW TO ORDER REPAIR PARTS

NOTE: When ordering service parts for any model Vac, follow the instructions listed below. By so doing, you will be assured of receiving the correct part in the shortest possible time.

1. Give the model and serial number, found on fan housing.
2. Write the complete part number as well as the description of the part, and quantity of part required.
3. Whenever the terms "left and right, or L and R" are used herein, it should be understood to mean from a position facing in direction of forward travel.

4. Give detailed shipping instructions, that is: whether shipment is to be by parcel post, United Parcel, air express, freight or truck.

NOTE: Parker Sweeper Co. is continually striving to improve its products. We must, therefore, reserve the right to make improvements or changes, when it becomes practical and possible to do so, without incurring any obligation to make changes or additions to the equipment previously sold.

CHASSIS & DRIVE ASSEMBLY

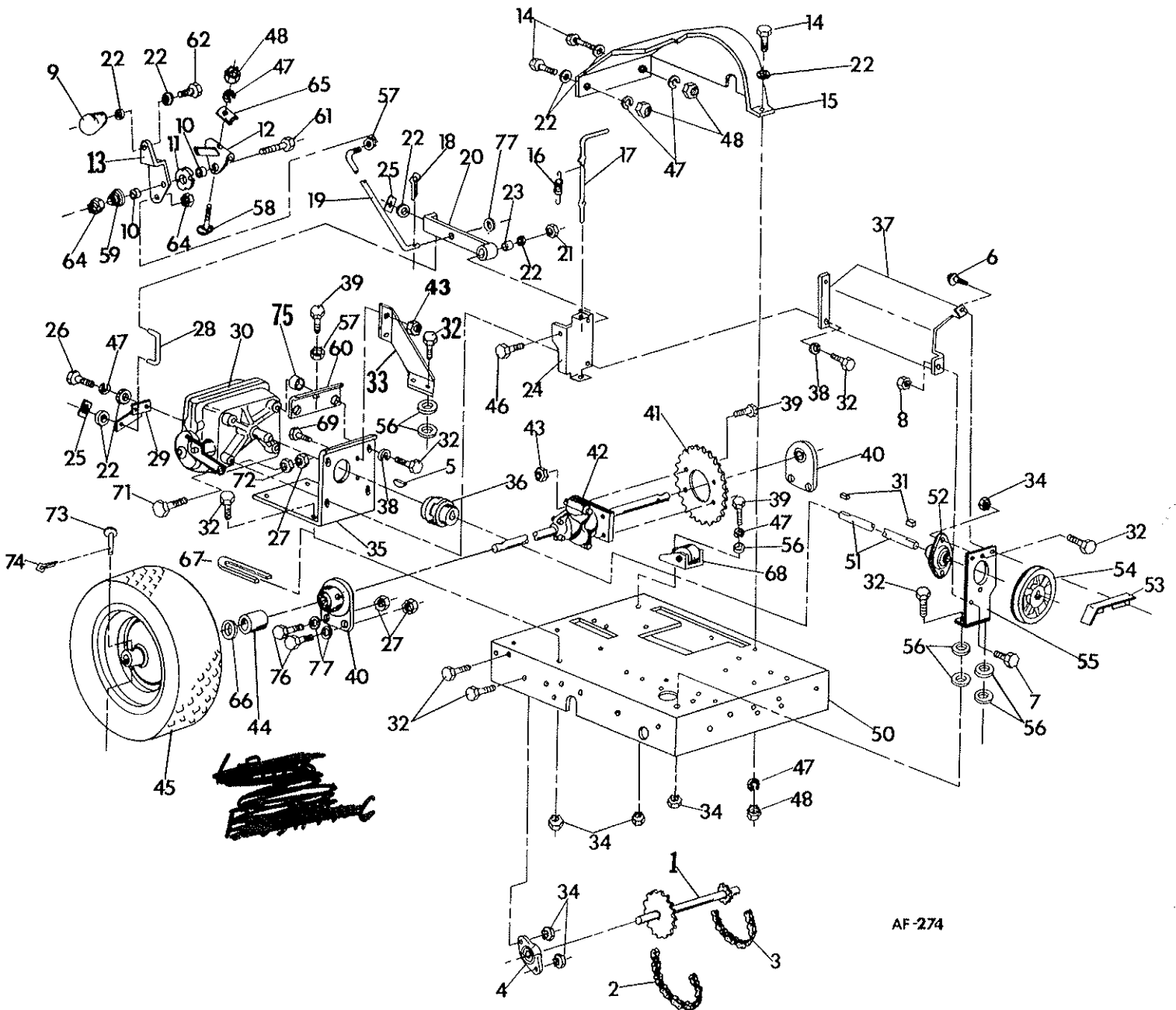

AF-274

REPAIR PARTS

SECTION 11
MODEL NO. PV-8108-AK-SP
PV-8108-AK-SP-LP

CHASSIS & DRIVE ASSEMBLY

PARTS LIST

Ref. No.	Part No.	Qty. Per Unit	Description	Ref. No.	Part No.	Qty. Per Unit	Description
1	81-25-B	1	Jack Shaft Weldment	40	SA-817-B	2	Bearing Assy. Modification
2	74-117-A	1	Chain, Roller #41-32p	41	74-100-C	1	Sprocket Differential, 40 Teeth
3	74-118-A	1	Chain, Roller #41-50p	42	SA-459-B	1	Differential Assy.
4	74-116-A	2	Bearing Assy. Side Flange	43	364-516	6	Nut, 5/16-18 Hex Lock Thin
5	280-09	1	#9 Woodruff Key Supplied	44	74-168-A	2	Wheel Spacer
6	530-7-6	2	Screw #7 x 3/8 Type A Sheet Metal	45	68-310-B	2	Wheel Assy.
7	515-10-6	1	Screw #10 x 24 x 3/8 Rd. Hd.		68-311-B	2	Wheel
8	365-10	1	Nut #10 x 24 Hex Lock		68-312-A	2	Tire 5.80/4.50x6
9	75-79-A	1	Shifter Knob	46	65-416-24	1	Bolt, 1/4-20 x 1 1/2 Hex Hd.
10	54-227-A	2	Spacer	47	935-416	4	Lockwasher 1/4 Spring
11	68-28-A	1	Cupped Washer	48	335-416	4	Nut, 1/4-20 Hex Plain
12	80-287-A	1	Stop & Bracket Weldment	50	81-19-D	1	Chassis
13	70-67-A	1	Shift Lever	51	74-88-A	1	Drive Shaft
14	65-416-8	3	Bolt 1/4-20 x 1/2 Hex Hd.	52	66-41-A	1	Seal Master Bearing
15	80-206-D	1	Chain Guard	53	75-94-B	1	Belt Guard
16	74-167-A	1	Spring, Brake	54	74-86-A	1	Sheave, Drive
17	74-96-A	1	Brake Lever	55	74-87-C	1	Bearing Bracket
18	57-110-A	1	Hair Pin	56	945-516	9	Washer 5/16 Flat
19	80-260-B	1	Speed Control Rod	57	335-516	2	Nut, 5/16 Hex Plain
20	80-254-A	1	Control Arm Assy.	58	69-416-24	1	Bolt 1/4-20 x 1 1/2 Contour Hd.
21	365-416	1	Nut, 1/4-20 Hex Lock	59	80-162-A	1	Shifter Spring
22	945-416	7	Washer 1/4 Flat	60	80-227-A	1	Adjusting Plate Weldment
23	75-10-A	1	Spacer	61	515-516-12	1	Screw
24	74-95-D	1	Shift Control Bracket	62	65-416-8	1	Hex Bolt 1/4-20 x 1/2
25	75-89-A	2	Speed Nut	64	364-516	2	Locknut, 5/16-18
26	60-416-10	1	Bolt, 1/4-28 x 3/8 Hex Hd.	65	80-181-A	1	Clamp
27	365-616	5	Nut, 3/8-16 Hex Lock	66	66-431-A	2	Washer
28	80-255-A	1	Speed Control Link	67	80-203-A	2	Bracket Spacer
29	SA-851-B	1	Shifter Linkage Weldment	68	SA-968-A	1	Tensioner-Chain
30	SA-857-A	1	Transmission	69	65-516-10	2	Bolt 5/16-18 x 3/8 Hex Hd.
31	48-277-A	2	Key, 3/16 Square	71	65-616-20	1	Bolt 3/8-16 Hex Hd.
32	65-516-12	20	Bolt, 5/16-18 x 3/4 Hex Hd.	72	335-616	1	Nut 3/8-16 Hex Plain
33	74-94-B	1	Transmission Bracket Brace	73	80-44-A	2	Clevis Pin
34	365-516	17	Nut 5/16-18 Hex Lock	74	380-332-8	2	Cotter Pin
35	74-93-C	1	Transmission Bracket	75	80-202-A	2	Spacer
36	74-114-A	1	Flexible Coupling	76	65-616-16	4	Bolt 3/8-16-1 Hex. Hd.
37	75-95-C	1	Shaft Guard	77	945-616	5	Washer 3/8 Flat
38	935-516	4	Lockwasher, 5/16 Spring				
39	65-516-16	6	Bolt, 5/16-18 x 1 Hex Hd.				

REPAIR PARTS

SECTION 11
MODEL NO. PV-8108-AK-SP
PV-8108-AK-SP-LP

HANDLE ASSEMBLY

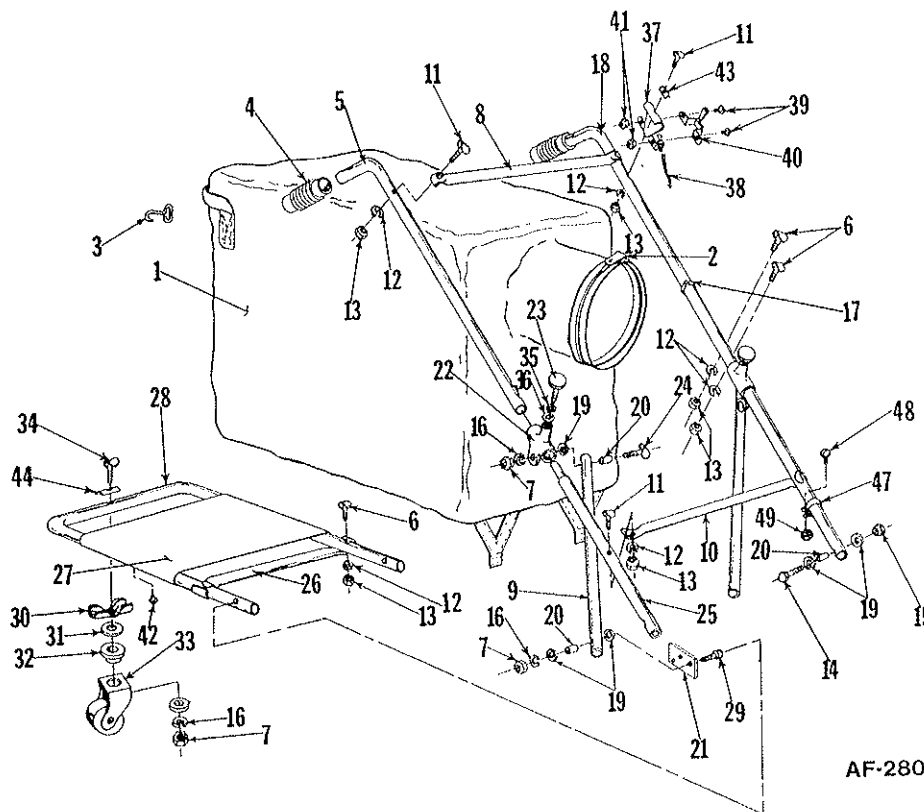

AF-280

PARTS LIST

Ref. Part No. No.	Description	Qty.		Ref. Part No. No.	Description	Qty.	
		Per Unit SP	SP-LP			Per Unit SP	SP-LP
1	Dust Bag Assembly	1	1	25	Middle Handle	2	2
2	Strap Assembly	1	1	SA-873-C	Bag Platform	1	1
3	Bag Hook	2	2	26	Cross Brace, Platform	1	1
4	Handle Grip	2	2	27	Bag Platform	1	1
5	Handles	2	2	28	Frame, Bag Platform	1	1
6	Bolt, ¼-20 x 1½ Contour Hd.	6	6	29	Pin Hinge	2	2
7	Nut, Hex Plain 5/16-18	5	5	30	Block, Pivot Bearing	1	1
8	Cross Brace, Upper	1	1	31	Washer - Special	1	1
9	Truss Brace	2	2	32	Bearing, Caster	1	1
10	Cross Brace, Lower	1	1	33	Caster Assembly	1	1
11	Bolt, ¼-20 x 1½ Contour Hd.	5	5	34	Bolt 5/16-18 x 2 Contour	1	1
12	Lock Washer, ¼ Spring	11	11	35	Split Lockwasher	2	2
13	Nut, ¼-20, Hex Plain	11	11	36	Int. Tooth Lockwasher	2	2
14	Bolt, 5/16-18 x 1¾ Hex. Hd.	4	4	37	SA-928 Stop Switch Assy.	1	1
15	Nut, 5/16-18, Hex Lock	2	2	38	81-21-A Switch Wire	1	1
16	Lockwasher 5/16 Spring	5	5	39	515-10-8 Screw 10-24-½ Rd. Hd.	2	2
17	Control Clamp, Snap	1	1	40	81-22-A Throttle Control Assy.	1	1
18	Nut, Hex Lock 8-32	2	2	41	365-10 Nut, Hex. Lock.	2	2
19	Flatwasher 5/16	10	10	42	77-27-A Screw, Self Tapping	1	1
20	Handle Inserts	6	6	43	80-181-A Clamp	1	1
21	Blag Platform bracket	2	2	44	59-77-A Clamp	1	1
22	Pivot Bracket	2	2	45	80-237-A Bag Guard	1	1
23	Knurled Torque Knob	2	2	46	80-267-A Plastic Tube Cape	1	1
24	Contour Bolt 5/16-18 x 1¾	2	2	47	81-88-A Wire Clamp	1	1
				48	515-8-8 Screw, Rd. Hd. 8-32-½	1	1

KOHLER ENGINE ASSEMBLY

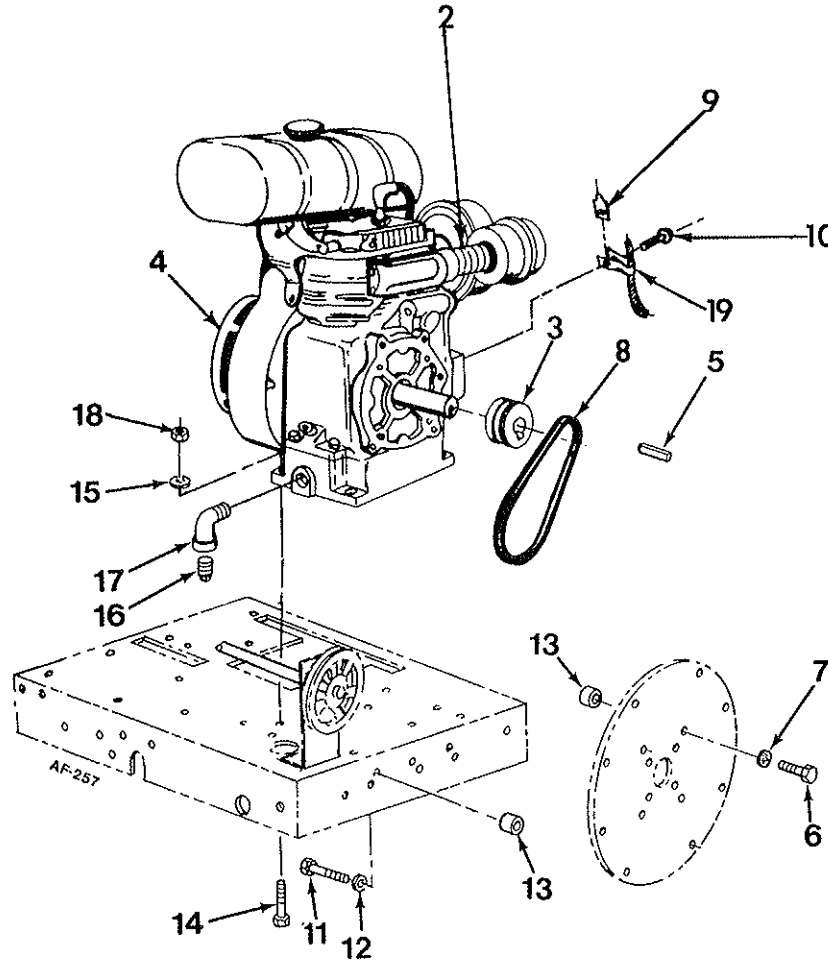

PARTS LIST

Ref. Part No. No.	Description	Quantity Per Unit		Ref. Part No. No.	Description	Quantity Per Unit	
		SP	SP-LP			SP	SP-LP
1	Engine Assembly	-	-	10 515-10-8	Screw 10-24 x 1/2 Rd. Hd.	1	1
2 67-68-A	Pipe Nipple 1 x 4	1	1	11 65-416-28	Bolt, 1/4-20 x 1 1/4 Hex. Hd.	2	2
3 74-119-A	Pulley, Engine	1	1	12 935-416	Lockwasher 1/4"	2	2
4 78-121-A	Engine, Kohler	1	1	13 73-414-A	Spacer, Back Cover	6	6
5 74-112-A	Fan Key 1/4 x 2 1/2	1	1	14 65-616-20	Bolt, 3/8-16 x 1 1/4 Hex. Hd.	4	4
6 65-616-24	Bolt, 3/8-16 x 1 1/4 Hex. Hd.	4	4	15 945-616	Flat Washer, 3/8"	4	4
7 935-616	Lock Washer, 3/8 Spring	4	4	16 **	Pipe Plug, Oil Drain	1	1
8 73-417-A	V Belt 3L-210	1	1	17 57-81-A	Street Elbow 1/2 x 90°	1	1
9 66-96-A	Speed Nut 10-24 U-Type	1	1	18 365-616	Nut, 3/8-16, Hex. Hd. Lock	4	4
				19 75-115-A	Throttle Cable Clip	1	1
				**	Supplied with engine		

*INSTALL
 COIL IN SECTION*

REPAIR PARTS

SECTION 11
MODEL NO. PV-8108-AK-SP
PV-8108-AK-SP-LP

HOUSING UNIT ASSEMBLY

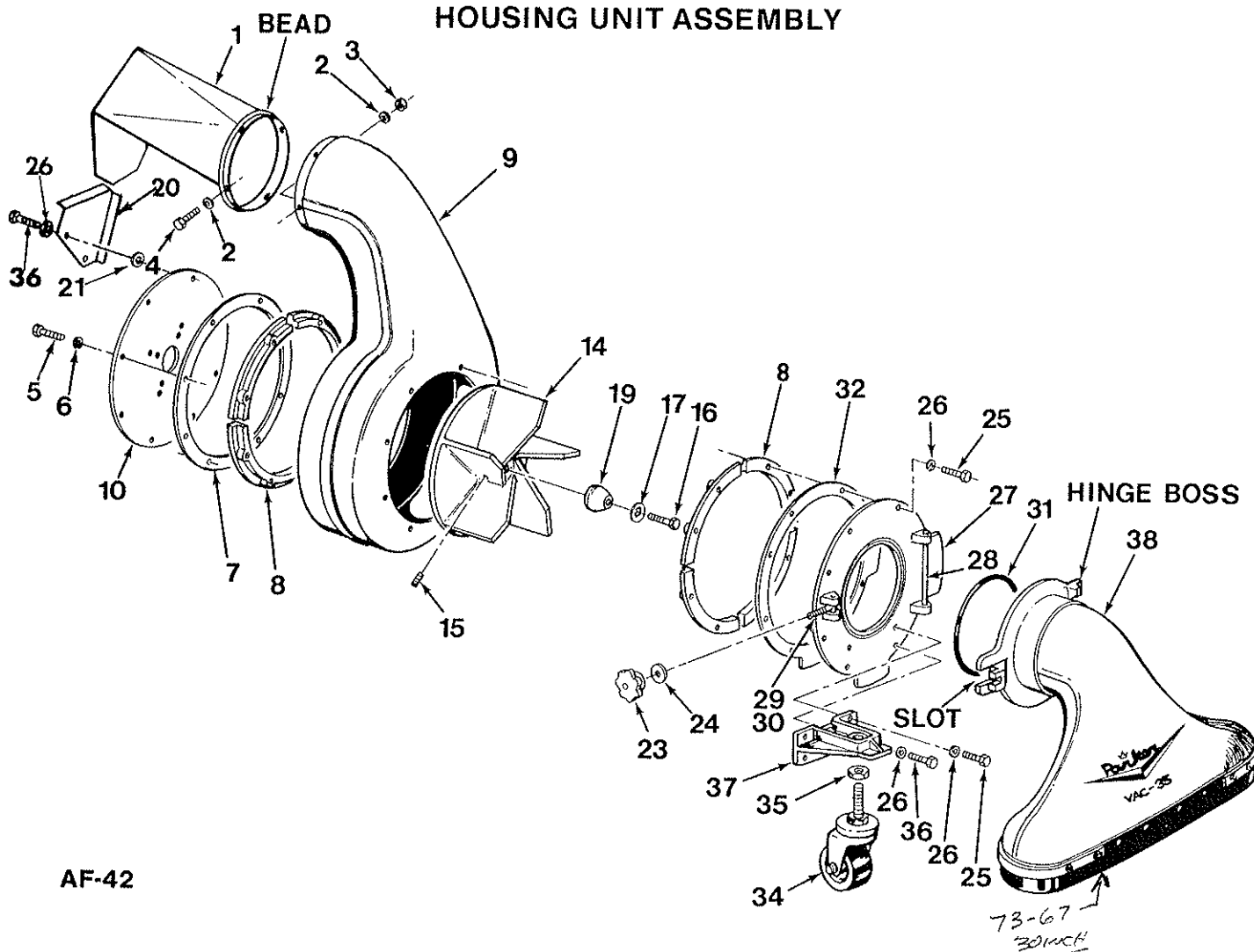

AF-42

PARTS LIST

Ref. No.	Part No.	Description	Quantity Per Unit		Ref. No.	Part No.	Description	Quantity Per Unit	
			SP	SP-LP				SP	SP-LP
1	68-308-B	Spin Pak, Deflector Weld.	1	1	24	945-816	Flat Washer, 1/2 SAE	1	1
2	945-416	Flat Washer, 1/4 SAE	8	8	25	65-416-16	Bolt, 1/4-20 x 1, Hex Head	6	6
3	364-416	Nut 1/4-20, Hex Hd., Lock, Thin	4	4	26	935-416	Lock Washer, 1/4 Spring	10	10
4	65-416-10	Bolt, 1/4-20 x 3/8, Hex Hd.	4	4	27	63-191-D	Front Cover	1	1
5	65-416-16	Bolt, 1/4-20 x 1 Hex Hd.	4	4	28	63-194-A	Hinge Pin	1	1
6	935-416	Lock Washer, 1/4 Spring	6	6	29	63-192-A	Pivot Bolt	1	1
7	62-187-C	Rubber Gasket	1	1	30	63-193-A	Roll Pin, 0.264 x 1 1/4	1	1
8	64-78-C	Anti-Wrap Segment	8	8	31	63-190-A	O-Ring, Gasket	1	1
9	70-103-F	Housing Assembly	1	1	32	75-03-C	Gasket, Front	1	1
10	73-430-C	Back Cover	1	1	34	64-71-A	Caster Stem Type	1	1
14	72-175-D	Fan Wheel	1	1	35	340-1216	Nut, 1/4-10, Hex. Jam	1	1
15	564-516-16	Setscrew	1	1	36	65-416-20	Bolt, 1/4-20 x 1 1/4, Hex. Hd.	4	4
16	65-39-A	Bolt, 7/16-20 x 2 1/2, Hex Hd.	1	1	37	66-430-C	Caster Bracket	1	1
17	936-716	Lock Washer, 7/16 Spring	1	1	38	SA-911-D	Intake Housing, 30"	1	1
19	73-119-A-3	Fan Retainer	1	1	38	MA-113-D	Intake Housing, 24"	*	*
20	72-241-B	Heat Shield	1	1	38	MA-120-D	Intake Housing, 36"	*	*
21	54-227-A	Spacer	2	2					
23	80-29-A	Adjusting Knob	1	1					
							* Purchased separate, optional accessory		

REPAIR PARTS

SECTION 11
MODEL NO. PV-8108-AK-SP-LP

L.P. GAS GROUP

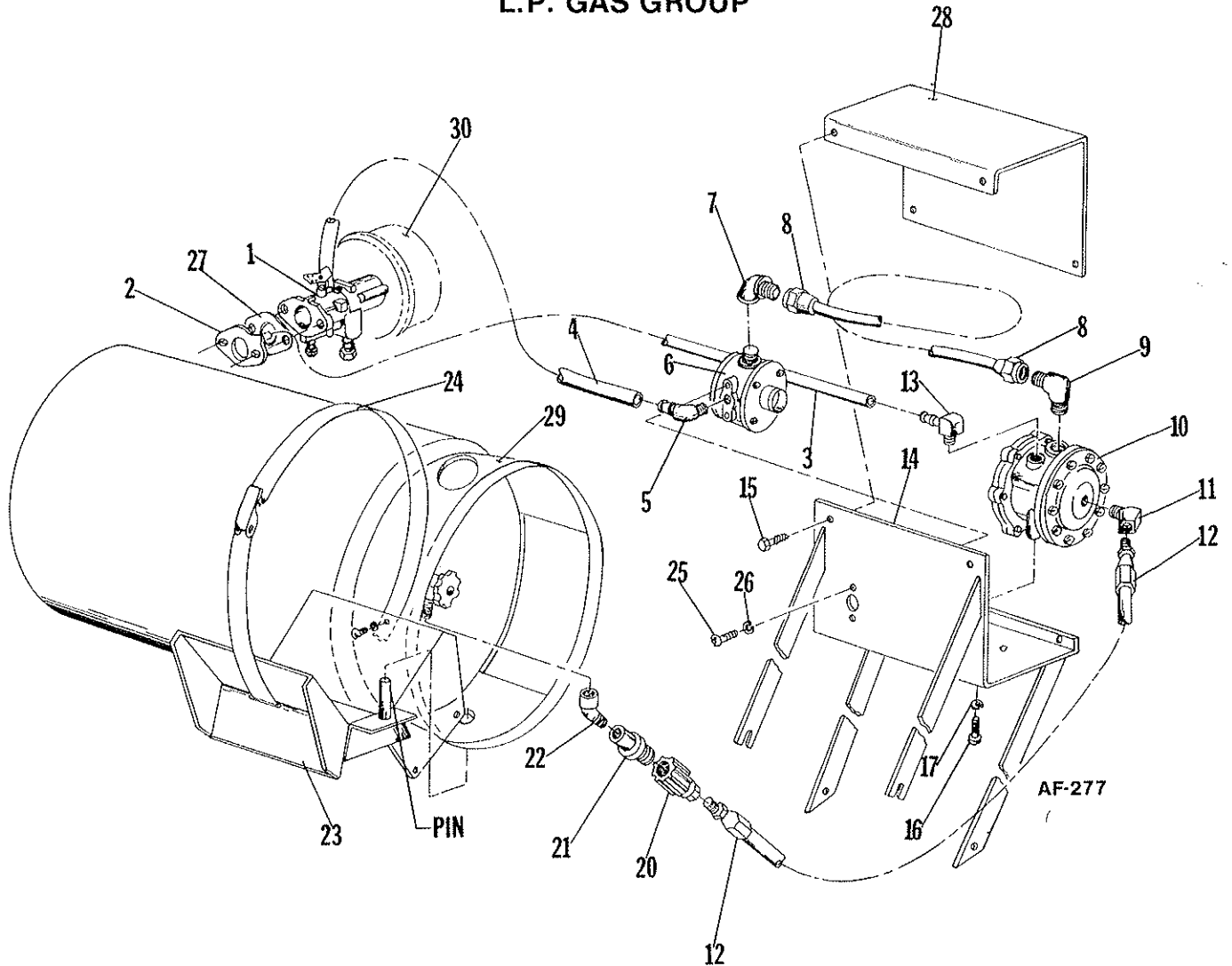

PARTS LIST

Ref. No.	Part No.	Description	Qty. Per Unit	Ref. No.	Part No.	Description	Qty. Per Unit
1	80-114-A	Carburetor	1	15	62-416-10	Bolt, Tapping, 1/4-28 x 3/8, Hex Hd.	4
2	80-121-A	Idler Plate	1	16	65-416-12	Bolt, 1/4-20 x 3/4, Hex Hd.	2
3	80-153-A	Line, Vacuum (Tube Only)	1	17	935-416	Lock Washer, 1/4 Spring	2
4	80-154-A	Fuel Line, Carb	1	20	62-252-A	Connector, Safety, Female	1
5	75-19-A	Hose Barb, 90°	2	21	62-253-A	Connector, Safety, Male	1
6	74-145-A	Pressure Regulator	1	22	73-234-A	Street Elbow, 3/8 x 45°	1
7	80-111-A	Elbow, Female	1	23	65-565-C	Bracket, Weldment, Tank	1
8	80-115-A	Fuel Line, Transfer Assembly	1	24	65-751-A	Band, Tank Holddown	1
9	80-113-A	Elbow, Male	1	25	515-8-8	Screw, 8-32 x 1/2, Rd. Hd.	2
10	72-228-A	Fuelock, Vacuum & Filter	1	26	935-8	Lock Washer, #8, Spring	2
11	75-18-A	Street Elbow, 1/4 x 45°	1	27	*210223	Gasket	2
12	74-152-A	Buel Line, Inlet Assembly	1	28	76-365	Cover, Regulator Mount	1
13	80-112-A	Elbow, Male (W/Nut & Sleeve)	1	29	67-69-B	Tank 14 Lb.	1
14	74-142-C	Bracket, Weldment	1	29	65-747-B	Tank 20 Lb.	1
				30	*231847	Air Cleaner	1

* Kohler Engines Part No.

PEERLESS TRANSMISSION

MODEL 750

Five Speed

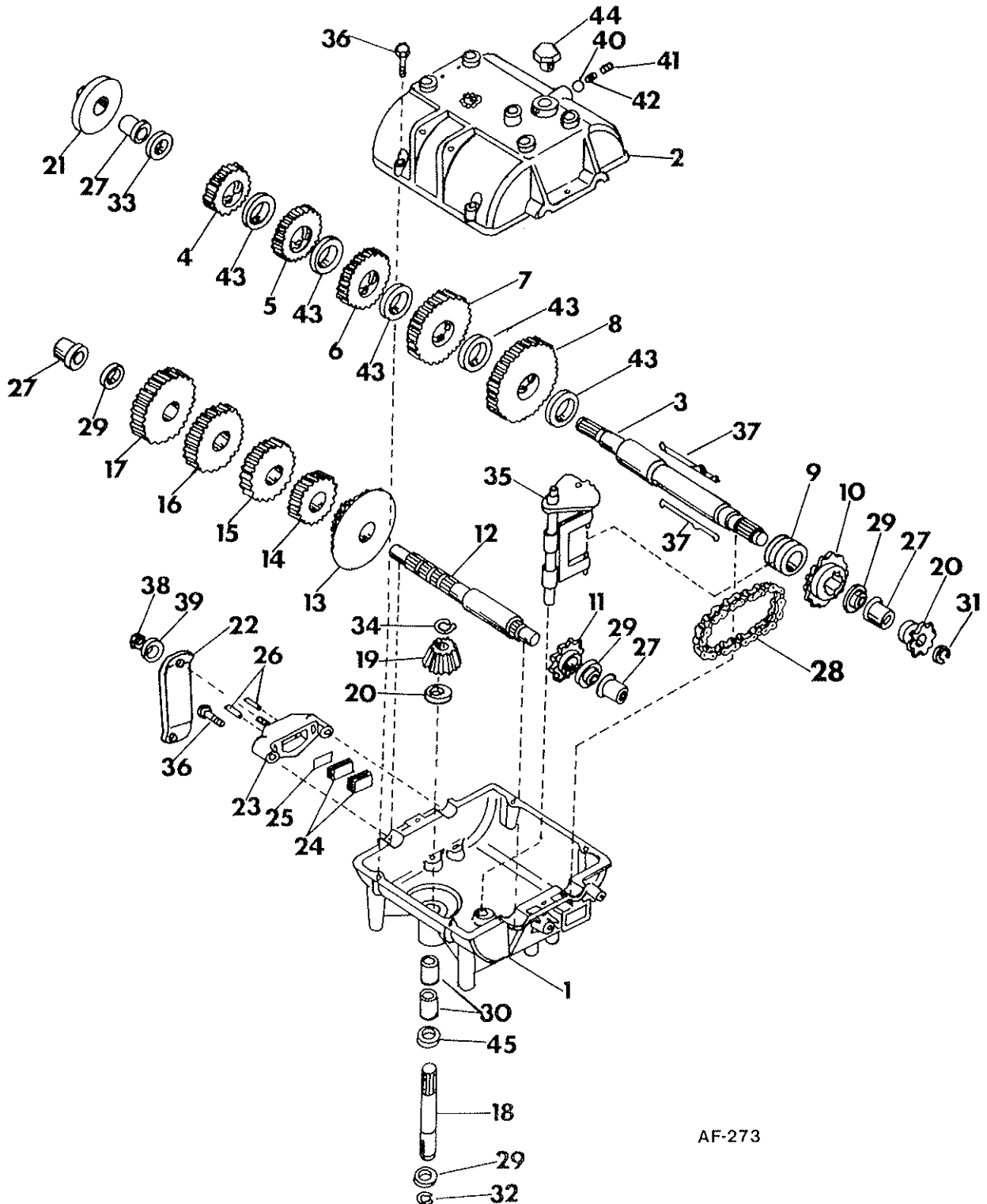

AF-273

PEERLESS "750" TRANSMISSION

PARTS LIST

Ref. No.	Part No.	Qty. Per Unit	Description	Ref. No.	Part No.	Qty. Per Unit	Description
1	770061	1	Case, Transmission	24	790006	1	Pad, Brake
2	772070	1	Cover, Transmission	25	790007	2	Plate, Brake pad
3	776161	1	Shaft, Output & brake	26	786026	2	Pin, Dowel
4	778121A	1	Gear, Spur (20 teeth)	27	780105	4	Bushing, Flanged
5	778122	1	Gear, Spur (22 teeth)	28	786062	1	Chain, Roller (# 41 chain, 22 links)
6	778123	1	Gear, Spur (25 teeth)	29	780072	5	Race, Thrust
7	778124	1	Gear, Spur (30 teeth)	30	780086	2	Bearing, Needle
8	778125	1	Gear, Spur (35 teeth)	31	792072	1	Ring, Retaining
9	784266	1	Collar	32	792035	1	Ring, Retaining
10	786060	1	Sprocket (14 teeth)	33	780109	1	Washer
11	786061	1	Sprocket (10 teeth)	34	788040	1	Ring, Retaining
12	776134	1	Shaft, Counter	35	784267	1	Rod & Fork Assy. Shift
13	778109	1	Gear, Bevel (42 tooth & 15 tooth)	36	792073	8	Screw, Hex Hd. Tapite, 1/4-20 x 1 1/4
14	778126A	1	Gear, Spur (20 teeth)	37	792089A	2	Key
15	778127A	1	Gear, Spur (25 teeth)	38	792075	2	Nut, Lock, 5/16-24
16	778128	1	Gear, Spur (28 teeth)	39	792076	1	Washer, Flat, 5/16
17	778129A	1	Gear, Spur (30 teeth)	40	792077	1	Ball, Steel 5/16
18	776135	1	Shaft, Input	41	792078	1	Screw, Set, 3/8-16 x 3/8
19	778113A	1	Bevel Pinion, Input	42	792079	1	Spring
20	786047	1	Sprocket (8 teeth)	43	780108	4	Washer, Thrush
21	790003	1	Disk, Brake	44	792074	1	Plug
22	790013	1	Lever, Brake	45	792001	1	Ring, Square Cut
23	790005	1	Holder, Brake pad				

REFER TO:
 TECHNISEH ENG. SERVICE (YK)

Order all parts from your nearest PARKER PARTS DISTRIBUTORS. If unable to locate the part from your Parts Distributor, forward your order to PARKER SWEEPER COMPANY for handling.

Hart-Greer, Inc. 900 N. 24th St. BIRMINGHAM, AL 35203	Morton B. Collins 300 Birnie Ave. SPRINGFIELD, MA 31106	Parker Sweeper Company P.O. Box 1728 SPRINGFIELD, OH 45501 Phone: 513-323-4901	Boyd Martin Company 1260 N.W. Temple SALT LAKE CITY, UT 84116
Lawn & Garden Supply Co. 2222 N. 27th Ave. PHOENIX, AZ 85017	Frost Company 483 Wildwood St. WOBURN, MA 01801	M.P.E. Sales, Inc. 25850 Chardon Rd. CLEVELAND, OH 44143	Denver Wholesale Florist Co. 1211 S. Swanner SALT LAKE CITY, UT 94104
Lawn & Garden Supply Co. 5455 S. Nogales Highway TUCSON, AZ 85706	Ideal Mower Sales, Inc. 811 Woodward Heights FERNDALE, MI 48220	Tri-County Sales & Service 15 North West Ave. YOUNGSTOWN, OH 44502	Wetsel Seed Co. 941 N. Liberty HARRISONBURG, VA 22801
H.V. Carter Company 1700 E. 14th St. OAKLAND, CA 94606	Lorenz Service Company 2500 S. Pennsylvania Ave. LANSING, MI 48220	Wait Sales Company 406-10 S. Peoria, Box 1015 TULSA, OK 74120	The Bentley Company 4126 Airport Way, S. SEATTLE, WA 98108
Tarzana Mower & Engine Parts, Inc. 6075 Reseda Blvd. RESEDA, CA 91335	R.L. Gould Company 3711 N. Lexington Ave. ST PAUL, MN 55112	Baltz & Son Co. 9817 E. Burnside PORTLAND, OR 97216	Northwest Mower, Inc. 926 N. 165th St. SEATTLE, WA 98133
Colorado Outdoor Equip., Inc. 527 W. Evans DENVER, CO 80223	Hance Distributors 420 Excelsior Ave., W. HOPKINS, MN 55343	Monroe Machinery & Supplies, Inc. 1421 S.E. Gidson St. PORTLAND, OR 97242	Interstate Radiator & Lawn Mower Co. 1611 4th Ave. CHARLESTON, WV 25312
Zaun Equipment Co. 2330 Bruner Ln., S.E. FORT MYERS, FL 33908	Gunthers Service & Supply 7320 Wornall Rd. KANSAS CITY, MO 64114	Lawn & Golf Supply Co. 647 Nutt Rd. PHOENIXVILLE, PA 19460	R.L. Gould 344 Berger St. GREEN BAY, WI 54302
Zaun Equipment, Inc. 1741 Hamilton St. JACKSONVILLE, FL 32210	Henzler, Inc. 2015 Lemay Ferry Rd. ST. LOUIS, MO 63125	Gardenville Supply Co., Inc. Route 611 PIPERSVILLE, PA 18947	Four Seasons Equipment, Inc. 7373 S. 6th St. OAK CREEK, WI 53154
Florida Turf & Garden 7275 N.W. 64th St. MIAMI, FL 33166	Port Huron Machinery & Supply 801 Q St. LINCOLN, NE 68508	Bluemont Co. 11125 Frankstown Rd. PITTSBURGH, PA 15235	Farm & Tiller Sales, Ltd. 1205 E. Hastings St. VANCOUVER, B.C., CANADA V6A155
Zaun Equipment, Inc., 1140 S. Rio Grande Ave. ORLANDO, FL 32806	George Smith & Sons, Inc. 322 Broadway BETHPAGE, L.I., NY 11714	Niemeyer Corp. 1135 Phoenixville Pike, Box 531 WEST CHESTER, PA 19380	Hoffars Sales, Ltd. 14251 Burrows Rd. RICHMOND, B.C., CANADA V6V 1K9
Zaun Equipment, Inc. 3032 44th Ave., N. ST. PETERSBURG, FL 33714	Grasslands Equip. & Irrigation 892 Troy Schenectady Rd. LATHAM, NY 12110	Fidelity Sales Corp. 6331 Baum Dr. KNOXVILLE, TN 37919	Robertson Seed, Ltd. 9241-48th St. EDMONTON, ALBERTA, CANADA T6B 2R9
Lawn & Turf, Inc. Hwy. Interstate 20, East CONYERS, GA 30207	Henry W. O'Neil & Associates, Inc. 410 N. Goodman St. ROCHESTER, NY 14609	Fidelity Sales Corp. 447 E. Market St. KINGSPORT, TN 37662	Morin Equipment, Inc. 90 Rue D'Anvers Parc Industriel ST. AUGUSTIN, QUEBEC, CANADA G0A 3E0
Boyd Martin Co. 4554 Chinden Blvd. BOISE, ID 83704	The Messinger Company, Inc. 374 Avery St. ROCHESTER, NY 14606	Fidelity Sales Corp. 6044 Lee Highway CHATTANOOGA, TN 37421	Morin Equipment, Inc. 270 Ave. Du Parc Industriel LONGUEVIL, MONTREAL, CANADA J4H 3V6
Geo. A. Davis 5440 Northwest Highway CHICAGO, IL 60630	American Hdwe. & Equip. 3940 Greensboro St. CHARLOTTE, NC 28206	Goldthwaite's of Dallas, Inc. 2700 Forest Ln., Box 34660 DALLAS, TX 75234	Uniquip Canada Ltd. 2813 Botham MONTREAL, QUEBEC, CANADA H4S 1H8
Plante's Lawn Equip., Inc. 1 Grant St. NORTH AURORA, IL 60542	Hayward Distributing Co. 460 Neilston St. COLUMBUS, OH 43215	Goldthwaite's of Ft. Worth 1401 Foch St. FT. WORTH, TX 76107	Duke Lawn Equipment 1184 Plains Road, East BURLINGTON, ONTARIO, CANADA L7S 1W6
F.E. Booher & Sons 1009 W. State St. ALBANY, IN 47320	Schroeder Sales & Service, Inc. 1144 Harrison Ave. HARRISON, OH 45030	Goldthwaite's of Houston, Inc. 220 Fariss HOUSTON, TX 77025	Uniquip Canada, Ltd. 6295 Shawson Dr., Unit 8 MISSISSAUGA, ONTARIO, CANADA L5T 1H4
Bruce Engine, Inc. 791 N.W. 86th St. DES MOINES, IA 50322	Hershman's, Inc. 12477 Benner Rd. RITTMAN, OH 44270	Goldthwaite's of Texas, Inc. 10751 Sentinel SAN ANTONIO, TX 78217	