

# OWNER'S GUIDE

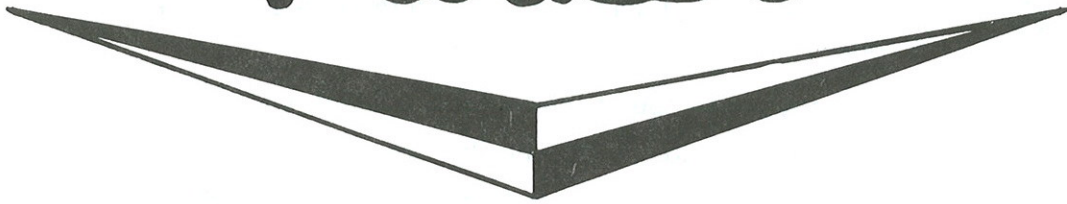

# Parker®



## VACUUM SWEEPER VAC-35 GASOLINE ENGINE MODEL NO. PV-8505-LA

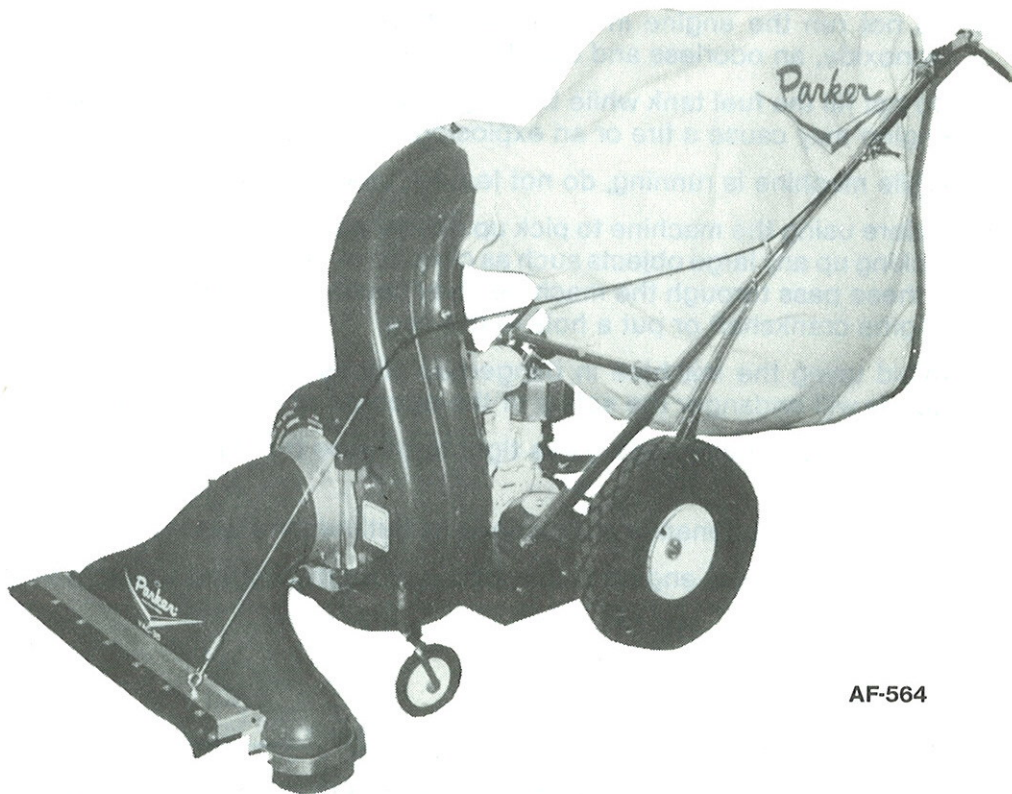

AF-564

**READ THESE INSTRUCTIONS  
BEFORE SETTING UP AND OPERATING MACHINE**

**BE SAFE. PROTECT YOUR FAMILY, YOUR FRIENDS, YOURSELF.  
OBSERVE ALL SAFETY INSTRUCTIONS.**

**PARKERSWEEPERCOMPANY    Box 1728    Springfield, Ohio 45501**

Plate No. 1092

## TO THE OWNER

These instructions were written to assist you in the assembly and operation of your Vac-35. **READ THE INSTRUCTIONS** thoroughly **BEFORE** attempting to assemble and operate the machine so that you are familiar with the complete procedure and the safety precautions.

### RULES FOR SAFE OPERATION



The following safety precautions are suggested to prevent damage to the equipment or injury to the operator or nearby persons.

1. Do not allow anyone to operate the Vac-35 without proper instructions.
2. Do not permit children to operate the Vac-35.
3. Do not sweep too close to fire. Ingesting hot ashes will ignite the bag.
4. Stop the engine before reaching into the intake nozzle or discharge chute to dislodge sticks or other debris.
5. Stop the engine before attempting to make any adjustment or performing any maintenance work on the Vac-35.
6. When working on the engine, always remove the spark plug wire from the engine and attach it to the V shaped clip on the engine head.
7. Do not run the engine in an enclosed area. Exhaust gases contain carbon monoxide, an odorless and deadly poison.
8. Do not fill the fuel tank while the engine is running. Spilling gasoline on a hot engine may cause a fire or an explosion.
9. While machine is running, do not leave it unattended.
10. Before using the machine to pick up debris, police the area to be cleaned first, picking up any large objects such as cans, toys, dog bones and chunks of wood. If these pass through the machine, they could damage the impeller, bend the engine crankshaft or put a hole in the bag.
11. Avoid using the machine in dangerous places where steep slopes or loose debris will endanger the safety of the operator or other people.
12. Keep all nuts, bolts and screws tight to be sure the Vac-35 is in safe working condition.
13. Follow the maintenance instructions as outlined in this manual.
14. Do not start or run engine unless bag is properly secured as injury may result.

### IMPORTANT

**ALWAYS GIVE THE FOLLOWING INFORMATION WHEN ORDERING REPAIR PARTS:**

- |                               |                        |
|-------------------------------|------------------------|
| 1. Part Number (Not Ref. No.) | 3. Description of Part |
| 2. Quantity Needed            | 4. Model No. of Vac-35 |

**If unable to obtain parts locally, write down above information and send to:  
PARKER SWEEPER CO., BOX 1728, SPRINGFIELD, OHIO 45501**

Your unit is right hand (R.H.) or left hand (L.H.) as you stand behind it.

## ASSEMBLY INSTRUCTIONS

**YOUR SAFETY IS OUR CONCERN. READ ALL SAFETY RULES AND OPERATING INSTRUCTIONS BEFORE ATTEMPTING TO OPERATE THIS EQUIPMENT. FAILURE TO FOLLOW SAFETY RULES AND OPERATING INSTRUCTIONS MAY RESULT IN SERIOUS INJURY.**

1. The Vac-35 covered in this owner's guide is shipped complete in one box. Follow all assembly instructions carefully. Whenever a difference in instructions occurs either a separate instruction or an "Explanation Note" will be given.
2. Unpack Intake Housing, Deflector and Retaining Ring, Upper Handle Assembly, Middle Handle Assembly, Dust Bag, and Hardware Package. All hardware needed for assembly is properly located on the preceding assemblies. If something is missing, notify a local distributor or the Parker Sweeper Company to obtain parts. DO NOT discard any part of the carton or inner packing until unit is completely assembled.
3. Tip box over so the rear of unit is toward floor. Pull unit out of box and stand it upright. Whenever the terms Left or Right Hand, or L. and R. are used herein, it should be understood to mean from a position standing behind the unit facing in a forward position.

### HANDLE ASSEMBLY (AF-565)

1. With the unit completely unpacked, allow handle back braces to lay on floor.
2. Remove the Hex Lock Nuts (thin), Hex Hd. Bolts, and Flatwashers from the ends of the Middle Handle Assembly, leaving inserts in place.
3. Align the ends of the Middle Handle Assembly with the top holes in the handle brackets.  
**NOTE:** The Middle Handle Assembly must be to the outside of handle brackets.
4. Replace hardware removed in step 2. DO NOT TIGHTEN. Allow middle handle assembly to lay back toward floor.
5. Remove the hardware from the two holes in both ends of the upper handle assembly.
6. Place upper handle assembly over the top ends of the middle handle assembly.
7. Align the lower holes in both the upper and middle handle assemblies. Replace one of the Hex Hd. Bolts, removed in step 5, in the lower right hand hole. Place the eye bolt, also from step 5, in the lower left hand hole. DO NOT REASSEMBLE HEX LOCK NUTS.
8. Lift upper and middle handle assemblies until back braces can be placed on eye bolt and Hex Hd. Bolt, assembled in step 7.
9. With back braces in place, assemble a Hex Lock Nut on both Hex Hd. Bolt and eye bolt. Do Not Tighten.

10. Align upper holes in upper and middle handle assemblies. Replace remaining hardware, removed in step 5, and tighten.
11. Tighten hardware used in lower holes.
12. Tighten hardware used to assemble middle handle assembly to handle brackets.

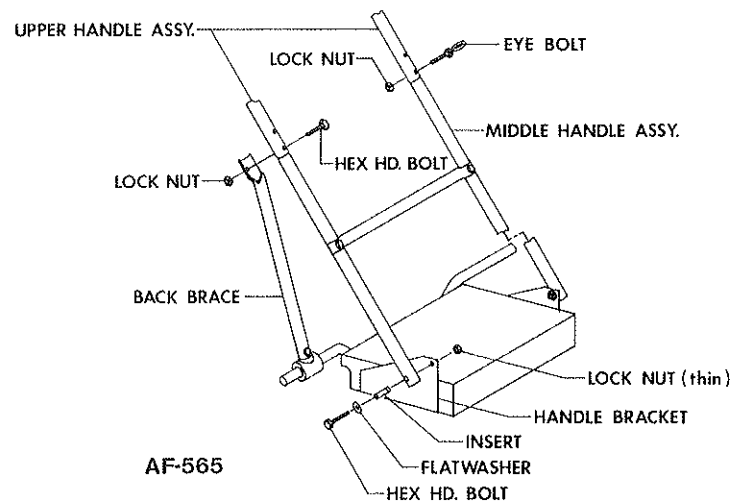

### THROTTLE CONTROL HOOKUP (AF-566)

1. To assemble throttle control, remove the throttle control from around the engine and straighten the throttle cable behind the unit.
2. Remove the snap-on clamp from the right hand middle handle assembly. Pull the bottom of the throttle cable to the left hand back brace and secure with snap-on clamp.
3. Remove the rd. hd. screws and lock nuts from the throttle control, by the lever, and continue to run cable up the left hand handle.  
**NOTE:** The throttle control lever must be on the outside of handle.
4. Place the rd. hd. screws through handle from inside, attach throttle control lever and secure with lock nuts.

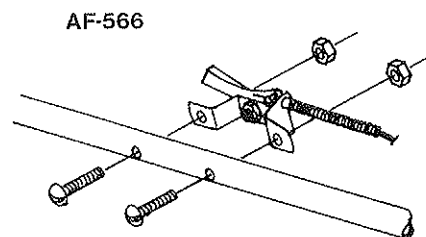

## ASSEMBLY INSTRUCTIONS (cont.)

**NOTE: FAILURE TO OBSERVE SAFETY INSTRUCTIONS MAY RESULT IN SERIOUS INJURY.**

### ATTACHING DEFLECTOR (AF-567)

1. Remove the hex hd. bolts, lock nuts, and flatwashers that hold the retaining ring to the neck of the blower housing. **DO NOT** remove retaining ring.
2. Align the holes in the Spin-Pak® with the three upper holes in the retaining ring and blower housing.
3. Replace hardware and tighten.

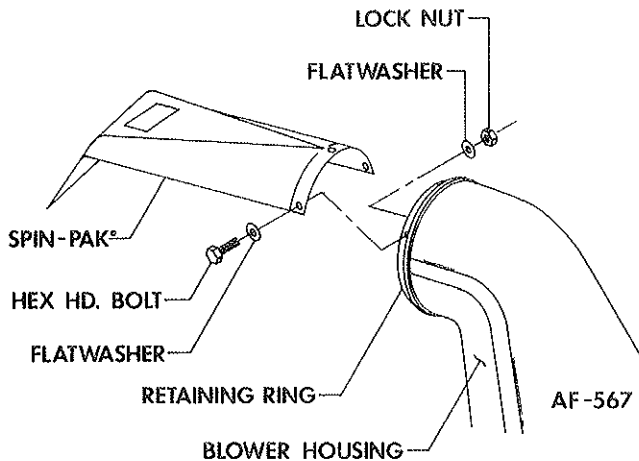

### ATTACHING DUST BAG

1. Attach the dust bag to the unit by placing the bag hooks over the upper and lower crossbars.
2. Slip the neck of the dust bag over the Spin-Pak® until the tie strap can be pulled tight around the housing neck just over the bead on the retaining ring. The bead must be covered.

**WARNING:** Failure to attach the front bag hooks to the lower crossbar can cause premature wear of bag and neck at the Spin-Pak®. The Spin-Pak® may also break prematurely due to excessive weight from the bag.

### ATTACHING INTAKE HOUSING

1. Insert the hinge bosses on collar of intake housing behind the hinge rod on front cover assembly.
2. Swing intake housing to lay flat against front cover assembly.
3. Secure by placing flatwasher and adjusting knob, on pivot bolt, over the collar of intake housing and tightening adjusting knob.

## OPERATING INSTRUCTIONS

### READ SAFETY & OPERATING INSTRUCTIONS BEFORE OPERATING EQUIPMENT

**WARNING:** the engine contains **NO OIL**. Read the Engine Instruction Manual carefully before operating the VAC-35. Be sure you know how to start and stop the engine before proceeding further. Do not start the engine until all assembly is finished.

Before starting the engine read and understand the following:

1. Be sure your engine crankcase is filled with the proper type and amount of oil.
2. Spin-Pak® is in place.
3. Dust Bag or Discharge Hose is in place.
4. Intake Housing or Hose Kit is attached to the Fan Housing.
5. Heavy concentration of sand and gravel should be avoided. These materials are extremely abrasive, and while the Vac-35 will handle moderate amounts of these materials, it is not designed for heavy applications. Because these materials are extremely heavy, only small amounts should be allowed to collect in the bag because large amounts cause poor handling and difficulty in pushing. The Vac-35 is capable of picking up empty tin cans and blocks of wood, but it was not intended for this type of service, since tremendous stresses build up as these pieces pass through the impeller. Treat your Vac-35 with reasonable care and it will repay you with long trouble-free service.

6. The Vac-35 will handle most common kinds of debris found around industrial plants, commercial buildings, homes and farms. Acid contaminated materials, magnesium, dust and other **DANGEROUS DEBRIS** that is considered hazardous should not be handled with the Vac-35 unless approved by a regulating authority considered to be an expert in the handling of such hazardous materials.

**DANGER:** Improper use of this equipment may result in serious injury.

### TO STOP ENGINE

The stop switch for the Briggs & Stratton engine on this unit is operated by the throttle control lever. To stop engine, back off on the throttle as far as possible; this works as an automatic stop switch on the engine.

**WARNING:** Allow engine to cool 2 or 3 minutes before refueling. Fuel spilled on a hot engine could ignite, resulting in serious damage to the unit and possible injury to the operator.

# MAINTENANCE INSTRUCTIONS

## DUST BAG CARE

1. To clean the dust bag, turn the bag inside out and reattach to the unit.
2. Start the engine and run at full throttle. Lightly tap the bag to release the dust trapped in the weave.
3. When the bag is clean, remove it and turn it right side out again. Reattach to the unit and resume sweeping.

The efficiency of the unit depends on the breathing capacity of the dust bag. Under extremely dusty conditions the bag should be emptied and cleaned frequently. Always empty and clean bag before storing after use. Debris allowed to remain in the bag may cause spontaneous combustion, resulting in an explosion or fire.

## LUBRICATION

1. The wheels on the Vac-35 should be checked periodically to assure proper lubrication is maintained. Grease fittings are located on the hubs of the rear wheels when lubrication is needed. The smaller front wheels should be removed, any grass or dirt cleaned from axle or hole through hub. Apply a light coat of grease on axles before replacing wheels.
2. A few drops of light oil on the throttle control, lever and cable, will keep it operating smoothly.
3. Refer to engine operating manual for proper lubrication of the engine.

## IMPORTANT INFORMATION

The Vac-35 is not equipped with a spark arrestor muffler. If the Vac-35 is to be used in the state of California, the state law requires spark arrestor mufflers be used to comply with Section 4442 of the California Public Resources Code. Contact your service center and have this muffler installed.

## OPTIONAL ACCESSORIES

**NOTE:** Accessory No. and Price List can be obtained from a local distributor.

**DISCHARGE HOSE KIT:** Attaches to exhaust port for leading debris into truck, container, etc.

**HOSE ATTACHMENT 6" DIA.:** 12 ft. length overall, fits all Vac-35 models. Attaches to impeller housing for cleaning debris from hard-to-reach areas.

**HOSE ATTACHMENT 4" DIA.:** 15 ft. length overall, fits all Vac-35 models. Attaches to impeller housing for cleaning debris from hard-to-reach areas.



## WARRANTY INFORMATION

Parker Sweeper Company warrants each new piece of equipment manufactured under its name except the engine, to be free of defects in materials and workmanship under normal use and service. Parker Sweeper Company's obligation is limited to repair or replacement at its option for one (1) year (ninety (90) days for commercial service) from date of purchase.

If trouble should occur with the engine, please contact the manufacturer, giving them all information: Name of unit, purchased from company, (Power Vac 8505-LA, Parker Sweeper Co., etc.); problem with engine, model number of engine, etc.; when unit was purchased; and a complete return address with zip code. Failure to provide complete information will result in unnecessary delay of repair and return of unit.

Proper assembly of replacement parts is the responsibility of the owner or mechanic doing the work. Parker Sweeper Company warranty only applies to the original purchased unit and/or replacement parts if assembled correctly by a qualified mechanic. Under no circumstances does the warranty extend beyond the original time specified from date of purchase.

### ENGINE:

Briggs & Stratton Company  
P.O. Box 702  
Milwaukee, Wisconsin 53201

**OBSERVE SAFETY RULES AT ALL TIMES. DON'T TAKE CHANCES!**

HANDLE ASSEMBLY

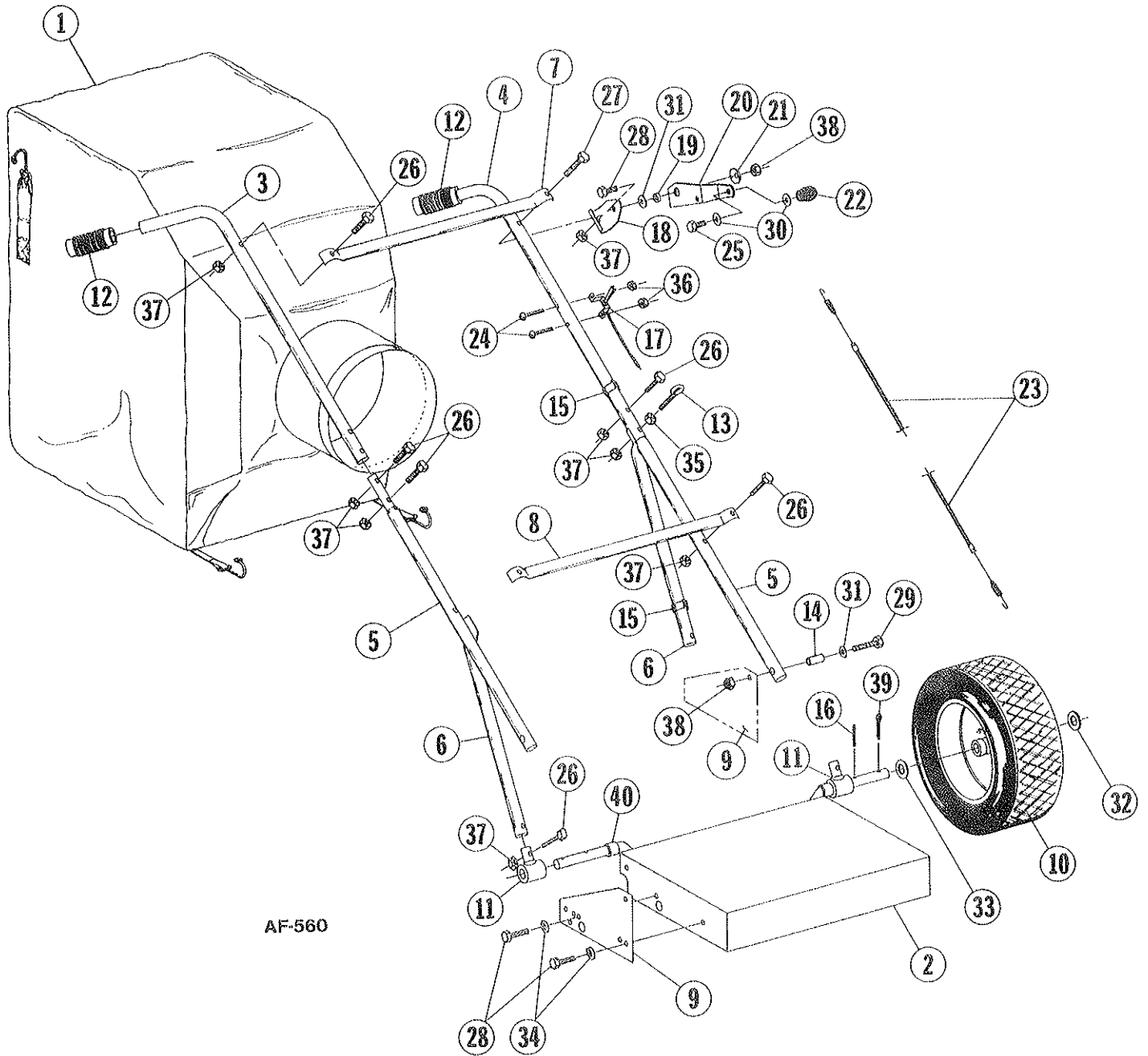

AF-560

## HANDLE ASSEMBLY

## PARTS LIST

Ref. No.	Part No.	Qty. Per Unit	Description
1	MA-585	1	Dust Bag
2	83-138-C	1	Chassis Weldment
3	80-321-C	1	Upper Handle, R.H.
4	83-18-C	1	Upper Handle, L.H.
5	82-245-B	2	Middle Handle
6	85-45-C	2	Handle Back Brace
7	81-04-B	1	Cross Bar, Upper
8	81-58-B	1	Cross Brace, Lower
9	73-362-C	2	Handle Bracket
10	SA-231-B	2	Wheel Assembly
11	85-44-B	2	Handle Back Brace Adaptor
12	80-232-A	2	Handle Grip
13	82-215-A	1	Eye Bolt 1/4-20 x 3
14	80-238-A	2	Insert
15	80-276-A	2	Snap-on Mounting Clamp
16	84-103-A	2	Roll Pin .199-.194 Dia. x 1 1/2
17	83-25-B-44	1	Throttle Control Assembly
18	83-17-A	1	Bracket
19	54-227-A	1	Spacer
20	85-22-B	1	Lever, Control
21	68-28-A	1	Cupped Spring Washer
22	75-79-A	1	Adjusting Knob
23	85-12-B	1	Intake Housing Cable
24	515-10-24	2	Screw, Rd. Hd. Mach. 10-24 x 1 1/2
25	65-416-8	1	Bolt, Hex Hd. 1/4-20 x 1/2
26	65-416-24	8	Bolt, Hex Hd. 1/4-20 x 1 1/2
27	65-416-28	1	Bolt, Hex Hd. 1/4-20 x 1 3/4
28	65-516-12	5	Bolt, Hex Hd. 5/16-18 x 3/4
29	65-516-24	2	Bolt, Hex Hd. 5/16-18 x 1 1/2
30	945-416	2	Flatwasher, Plain 1/4
31	945-516	3	Flatwasher, Plain 5/16
32	945-1216	2	Flatwasher, Plain 3/4
33	960-1216	2	Flatwasher 3/4
34	935-516	4	Lockwasher, Spring 5/16
35	335-416	1	Nut, Plain Hex 1/4-20
36	365-10	2	Nut, Hex Lock 10-24
37	365-416	10	Nut, Hex Lock 1/4-20
38	364-516	3	Nut, Hex Lock (thin) 5/16-18
39	380-432-20	2	Pin, Cotter 1/8 x 1 1/4
40	85-89-A	2	Spacer

HOUSING ASSEMBLY

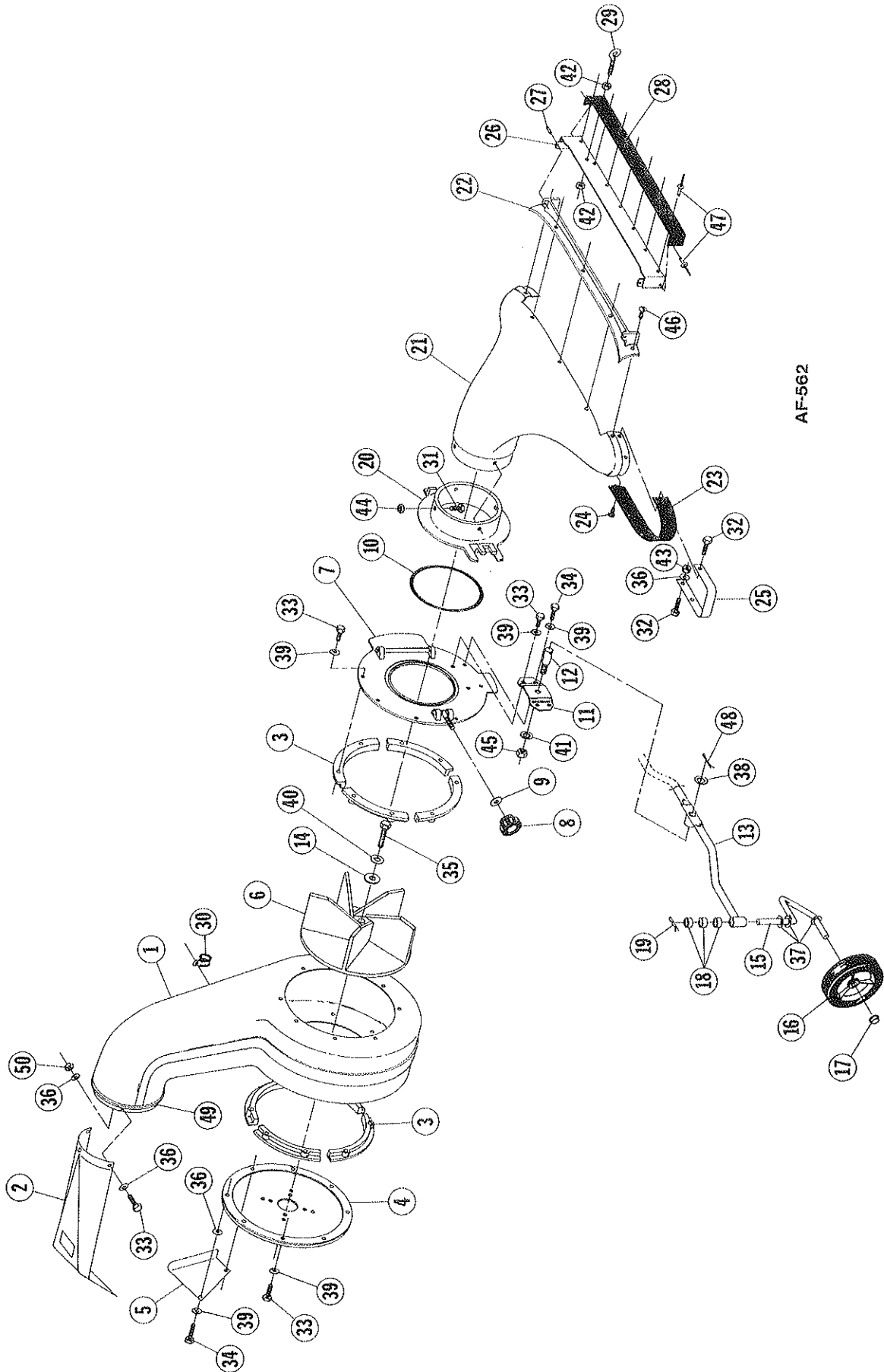

AF-562



## HOUSING ASSEMBLY

## PARTS LIST

Ref. No.	Part No.	Qty. Per Unit	Description
1	70-103-F	1	Housing Assembly
2	85-110-B	1	Spin Pak®
3	64-78-C	8	Anti-Wrap Segment
4	84-239-C	1	Back Plate & Gasket
5	81-194-D	1	Heat Shield
6	61-14-D	1	Fan Wheel
7	63-225-D	1	Front Cover Assembly
*8	80-29-A	1	• Adjusting Knob
*9	945-816	1	• Flatwasher, Plain 1/2
*10	63-190-A	1	• O-Ring Gasket
11	73-89-B	1	Mount Plate
12	73-94-A	1	Pivot Pin
13	83-211-B	1	Axle Support Weldment
14	82-138-B-1	1	Washer Special
15	83-209-B	2	Axle
16	84-300-C	2	Wheel
17	76-254-A	2	End Cap
18	79-16-A	6	Spacer
19	81-106-A	2	Cotter Hair Pin
20	63-195-D	1	Collar
21	83-131-D	1	30" Intake Housing (Mod.)
22	83-185-B	1	Intake Door Housing
23	83-135-D	1	Back Skirt
24	80-332-A	9	Fastener
25	83-136-C	2	Guard
26	83-214-C	1	Door Weldment
27	69-98-A	2	Roll Pin
28	83-148-C	1	Door Skirt
29	84-80-A	1	Eye Bolt
30	82-54-A	1	Clamp
31	65-416-10	4	Bolt, Hex Hd. 1/4-20 x 5/8
32	65-416-12	6	Bolt, Hex Hd. 1/4-20 x 3/4
33	65-416-16	16	Bolt, Hex Hd. 1/4-20 x 1
34	65-416-20	4	Bolt, Hex Hd. 1/4-20 x 1 1/4
35	60-516-16	1	Bolt, Hex Hd. 5/16-24 x 1
36	945-416	16	Flatwasher, Plain 1/4
37	945-816	6	Flatwasher, Plain 1/2
38	945-1216	1	Flatwasher, Plain 3/4
39	935-416	16	Lockwasher, Spring 1/4
40	935-516	1	Lockwasher, Spring 5/16
41	936-816	1	Lockwasher, Int. Tooth 1/2
42	335-416	2	Nut, Plain Hex 1/4-20
43	364-416	6	Nut, Hex Lock (Thin) 1/4-20
44	369-416	4	Nut, Serrated Hex Lock 1/4-20
45	345-816	1	Nut, Hex Jam 1/2-20
46	504-416-8	5	Screw, Rd. Hd. Mach. Self Tapping Type F
47	411-6-527AA	9	Pop Rivet
48	380-532-20	1	Cotter Pin 5/32 x 1 1/4
49	85-59-C	1	Retaining Ring
50	365-416	4	Nut Hex Lock 1/4-20

\*Items 8, 9, & 10 are supplied with item 7, but can be purchased separately.

ENGINE ASSEMBLY

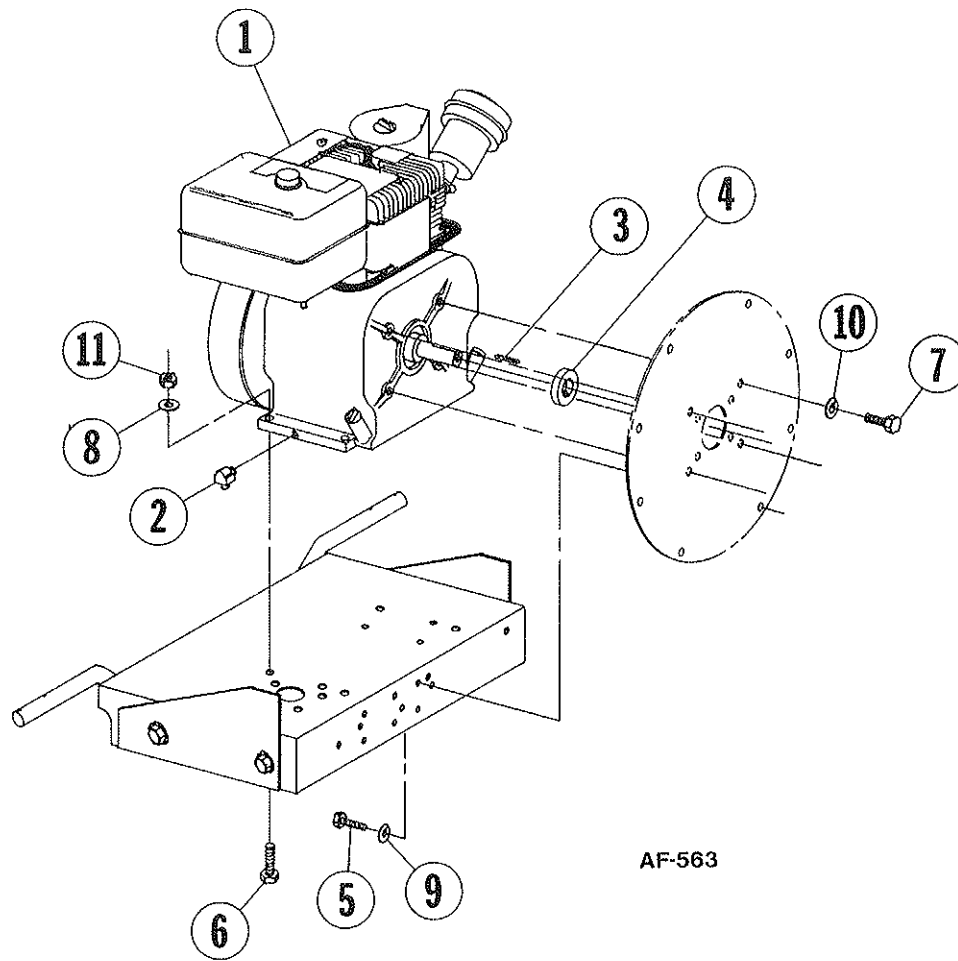

AF-563

PARTS LIST

Ref. No.	Part No.	Qty. Per Unit	Description
*1	85-46-D	1	Engine, B&S I/C 5HP
2	61-25-A	1	Street Elbow 1/4 x 90°
3	61-65-A	1	Fan Key 3/16 sq. x 1 3/4 LG.
4	64-134-A	1	Fan Spacer
5	65-416-20	2	Bolt, Hex Hd. 1/4-20 x 1 1/4
6	65-516-24	4	Bolt, Hex Hd. 5/16-18 x 1 1/2
7	60-516-10	4	Bolt, Hex Hd. 5/16-24 x 5/8
8	945-516	4	Flatwasher, Plain 5/16
9	935-416	2	Lockwasher, Spring 1/4
10	935-516	4	Lockwasher, Spring 5/16
11	365-516	4	Nut, Hex Lock 5/16-18

\*B&S Model No. 132412 Spec. 0222-01